

brother.

INSTRUCTION BOOK FOR SERGER

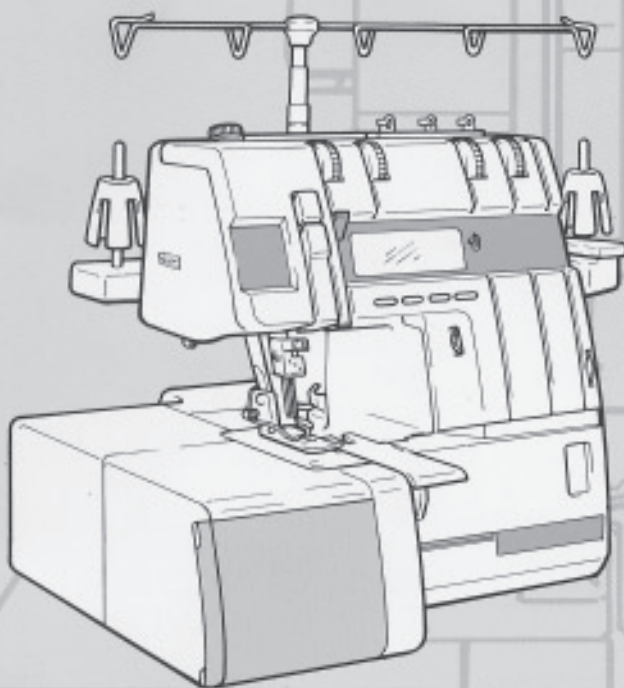

“IMPORTANT SAFETY INSTRUCTIONS”

When using the sewing machine, basic safety precautions should always be followed, including the following.

“Read all instructions before using.”

DANGER — To reduce the risk of electric shock.

1. The sewing machine should never be left unattended when plugged in. Always unplug this sewing machine from the electrical outlet immediately after using and before cleaning.
2. Always unplug before relamping. Replace bulb with same type rated 2.4 watts.

WARNING — To reduce the risk of burns, fire, electric shock, or injury to persons.

1. Do not allow to be used as a toy. Close attention is necessary when the sewing machine is used by or near children.
2. Use this sewing machine only for its intended use as described in this manual. Use only accessories recommended by the manufacturer as contained in this manual.
3. Never operate this sewing machine if it has a damaged cord or plug, if it is not working properly, if it has been dropped or damaged, or dropped into water. Return the sewing machine to the nearest authorized dealer or service center for examination, repair, electrical or mechanical adjustment.
4. Never operate the sewing machine with any air openings blocked. Keep ventilation openings of the sewing machine and foot control free from the accumulation of lint, dust, and loose cloth.
5. Never drop or insert any object into any opening.
6. Do not use outdoors.
7. Do not operate where aerosol (spray) products are being used or where oxygen is being administered.
8. To disconnect, turn the main switch to the symbol “O” position which represents off, then remove plug from outlet.
9. Do not unplug by pulling on cord. To unplug, grasp the plug, not the cord.
10. Keep fingers away from all moving parts. Special care is required around the sewing machine needle.
11. Always use the proper needle plate. The wrong plate can cause the needle to break.
12. Do not use bent needles.
13. Do not pull or push fabric while stitching. It may deflect the needle causing it to break.
14. Switch the sewing machine to the symbol “O” position when making any adjustments in the needle area, such as threading needle, changing needle, threading bobbin, or changing presser foot, and the like.
15. Always unplug the sewing machine from the electrical outlet when removing covers, lubricating, or when making any of the user servicing adjustments mentioned in the instruction manual.
16. This sewing machine is not intended for use by young children or infirm persons without supervision.
17. Young children should be supervised to ensure that they do not play with this sewing machine.

“SAVE THESE INSTRUCTIONS”

“This sewing machine is intended for household use.”

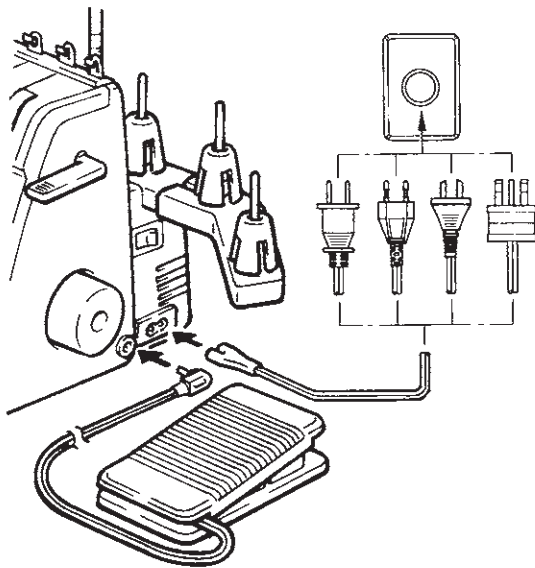

- When leaving the sewing machine unattended, the main switch of the machine must be switched off or the plug must be removed from the socket-outlet.

- When servicing the sewing machine, or when removing covers or changing lamps, the machine or the electrical set must be disconnected from the supply by removing the plug from the socket-outlet.

FOR USERS IN THE UK, EIRE, MALTA AND CYPRUS ONLY.

If your sewing machine is fitted with a 3 pin non rewirable BS plug then please read the following.

IMPORTANT

If the available socket outlet is not suitable for the plug supplied with this equipment, it should be cut off and an appropriate three pin plug fitted. With alternative plugs an approved fuse must be fitted in the plug.

NOTE: The plug severed from the mains lead must be destroyed as a plug with bared flexible cords is hazardous if engaged in a live socket outlet. In the event of replacing the plug fuse, use a fuse approved by ASTA to BS 1362, i.e. carrying the  mark, rating as marked on plug.

Always replace the fuse cover, never use plugs with the fuse cover omitted.

WARNING: DO NOT CONNECT EITHER WIRE TO THE EARTH TERMINAL WHICH IS MARKED WITH THE LETTER 'E', BY THE EARTH SYMBOL  OR COLOURED GREEN OR YELLOW.

The wires in this mains lead are coloured in accordance with the following code:

Blue	Neutral
Brown	Live

As the colours of the wiring in the mains lead of this appliance may not correspond with the coloured markings identifying the terminals in your plug, proceed as follows.

The wire which is coloured blue must be connected to the terminal which is marked with the letter 'N' or coloured black or blue.

The wire which is coloured brown must be connected to the terminal which is marked with the letter 'L' or coloured red or brown.

CONGRATULATIONS ON CHOOSING THIS COMPACT OVERLOCK

Your machine is a high quality, easy-to-use product. To fully enjoy all the features, we suggest that you study this booklet. If you need more information regarding the use of your machine, your nearest authorized dealer is always happy to be of service.
Enjoy yourself!

CAUTION!

WHEN THREADING, REPLACING NEEDLE OR LIGHT BULB, BE SURE TO TURN OFF THE MAIN POWER SWITCH OF THE MACHINE.

WHEN THE MACHINE IS NOT IN USE, IT IS RECOMMENDED THAT THE ELECTRIC SUPPLY PLUG IS DISCONNECTED FROM THE WALL SOCKET TO AVOID ANY POSSIBLE HAZARDS.

CAUTION!

THIS APPLIANCE HAS A POLARIZED PLUG (ONE BLADE WIDER THAN THE OTHER). TO REDUCE THE RISK OF ELECTRIC SHOCK, THIS PLUG IS INTENDED TO FIT IN A POLARIZED OUTLET ONLY ONE WAY.

IF THE PLUG DOES NOT FIT FULLY IN THE OUTLET, REVERSE THE PLUG.

IF IT STILL DOES NOT FIT, CONTACT A QUALIFIED ELECTRICIAN TO INSTALL THE PROPER OUTLET.
DO NOT MODIFY THE PLUG IN ANY WAY.

FOOT CONTROLLER: MODEL P

NOTE (FOR U.S.A. ONLY):

THIS FOOT CONTROLLER CAN BE USED FOR SEWING MACHINE MODEL PL2100

TABLE OF CONTENTS

NAMES OF PARTS AND THEIR FUNCTIONS	1-2
ACCESSORIES	3-4
HOW TO USE THE SEWING ADVISOR FUNCTION	5-6
Basic operation	
Explanation of troubleshooting screen	
SETTING UP YOUR MACHINE	7
Motor	
NEEDLE	8-10
For cover stitch model	
THREADING	11-15
Before threading...	
Threading upper looper	
Threading lower looper	
Threading the double chain stitch looper thread	
THREADING NEEDLES	16-17
1) Right needle thread	
2) Threading the left needle thread	
3) Double chain stitch needle thread	
4) Threading the right needle for model without LCD	
USING THE COVER STITCH FUNCTION	18-20
Replacing the presser foot	
Tri-cover stitch (Three needles four threads cover stitch)	
Two needles three threads cover stitch	
THREADING FOR COVER STITCH	21-23
Looper	
Needle thread-front right (FRN) and front center (FCN)	
Needle thread-front left (FLN)	
Needle thread-front center (FCN)	
ACTUAL EXAMPLES OF TWO NEEDLES THREE THREADS COVER STITCH SEWING	23
ACTUAL EXAMPLES OF THREE NEEDLES FOUR THREADS COVER STITCH SEWING	24
STITCH SELECTION	25-26
THREAD SETTING FOR VARIOUS STITCHES	27-28
Five-thread overlock stitch	
Four-thread overlock stitch	
Three-thread overlock stitch	
Double chain stitch	
SETTING FOR DOUBLE CHAIN STITCH SEWING	29-31
1. Retracting the upper looper for chain	
2. Retracting the upper cutter	
3. Removal and installation of cutter cover II	
SETTING FOR TWO-THREAD OVERLOCK STITCH SEWING	32
SEWING	33-34
Four-thread, three-thread or two-thread sewing	
Five-thread or double chain stitch sewing	
THREAD TENSION ADJUSTMENT	35-38
RELATIONSHIP BETWEEN SEWING MATERIAL, THREAD AND NEEDLE ...	39
STITCH LENGTH AND STITCH WIDTH	40
Stitch length	
Stitch width	
STITCH WIDTH AND CUTTING WIDTH FINE-TUNE ADJUSTMENT	41
DIFFERENTIAL FEED	42
PRESSER FOOT	43
NARROW OVERLOCK STITCH/ROLLED EDGE STITCH	44-45
EXAMPLES OF SEWING APPLICATIONS FOR OVERLOCK SEWING MACHINES	46-47
COVER STITCH ATTACHMENT SET (OPTIONAL).....	48
PERFORMANCE PROBLEMS	49-50
CHANGING THE LIGHT BULB	51
MAINTENANCE	52

NAMES OF PARTS AND THEIR FUNCTIONS

Speed selector

(Fast)

1

1/2

(Slow)

Rated lamp bulb: 8V 2.4W

LAMP MAX 24W

18

OFF ON

LCD contrast adjustment dial

Dark

Light

30

Cutter cover II

CAUTION!
Close the front cover before operating the machine.

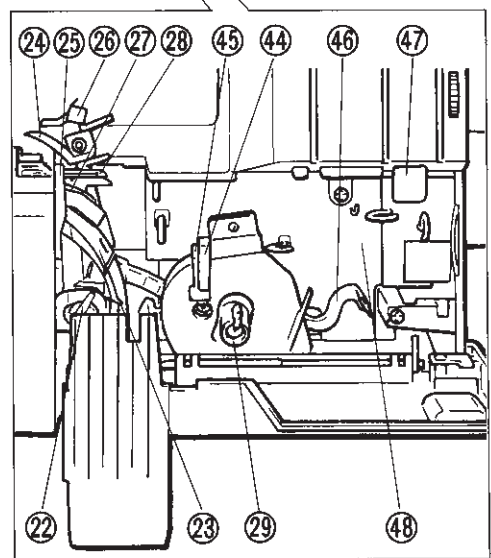
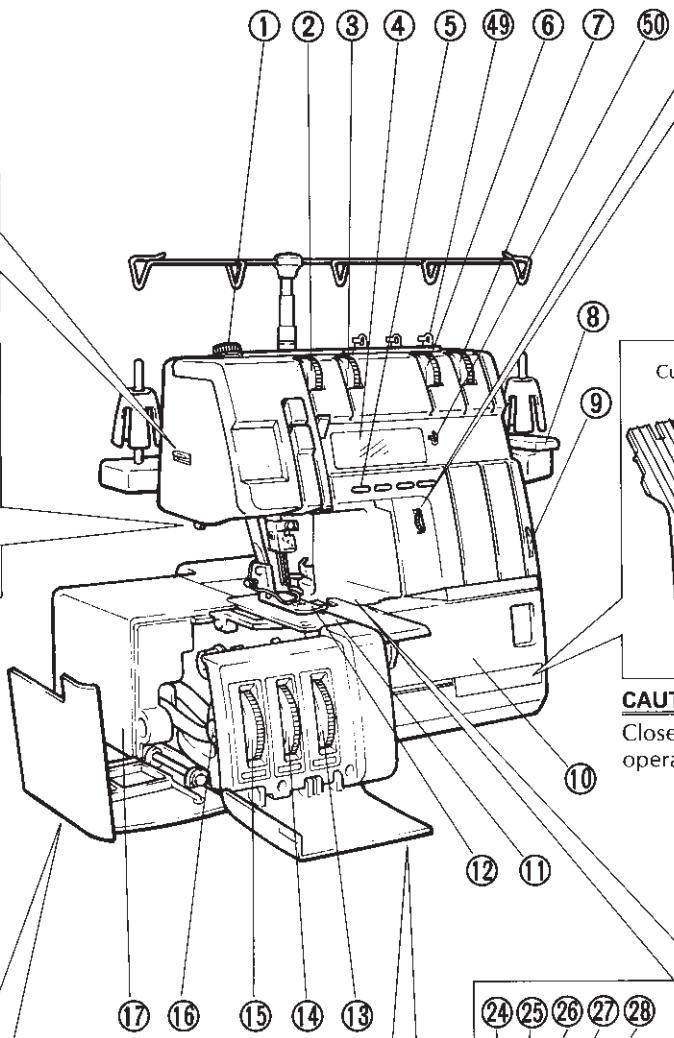

19

20

CAUTION!
Close the side cover before operating the machine.

21

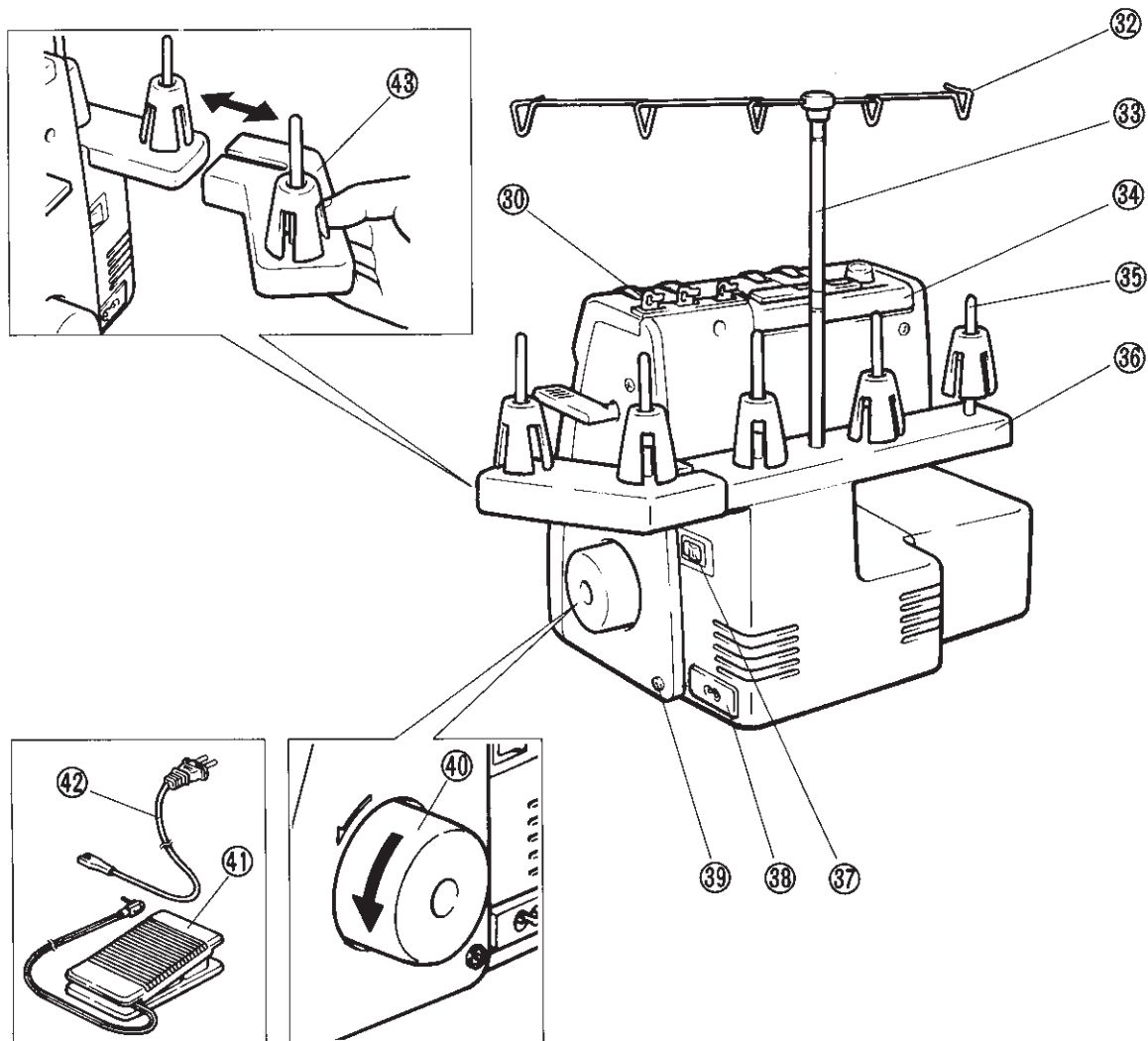

- | | | |
|---|---|--|
| ① Pressure adjustment dial | ⑮ Differential feed control dial | ⑳ Thread holder stand |
| ② Thread tension dial for left needle thread (and for double chain stitch thread) | ⑯ Cutter retracting knob | ㉑ Handle |
| ③ Thread tension dial for right needle thread and FCN & FRN | ⑰ Side cover (rear) | ㉒ Spool pin |
| ④ Liquid crystal display (LCD) | ⑱ Light switch | ㉓ Spool support |
| ⑤ Liquid crystal display keys | ⑲ Material plate cover (front) | ㉔ Main power switch |
| ⑥ Thread tension dial for upper looper thread and FCN | ㉑ Double chain stitch looper threading knob | ㉕ Power cord socket |
| ⑦ Thread tension dial for lower looper thread | ㉒ Control cover | ㉖ Foot control jack |
| ⑧ Presser foot lever | ㉓ Stitch finger lever | ㉗ Handwheel |
| ⑨ Thread tension dial (For double chain stitch looper thread) | ㉔ Lower looper threading lever | ㉘ Foot control |
| ⑩ Front cover | ㉕ Upper looper | ㉙ Power cord |
| ⑪ Needle plate | ㉖ Movable stitch finger | ㉚ Spool support for double chain stitch thread |
| ⑫ Presser foot | ㉗ 2/3 Thread converter lever | ㉛ Upperlooper thread take up |
| ⑬ Stitch width control dial | ㉘ Double chain stitch looper | ㉜ Lowerlooper thread take up |
| ⑭ Stitch length control dial | ㉙ Lower looper | ㉝ Coverstitch thread take up |
| | ㉚ Chain stitch lever (Upper looper release lever) | ㉞ Chainlooper thread release lever |
| | ㉛ LCD contrast adjustment dial | ㉟ Cover stitch check spring |
| | ㉜ Thread guide | ㊱ Thread guide (decorative thread only) |
| | ㉝ Thread holder | ㊲ Thread guide FCN |

ACCESSORIES

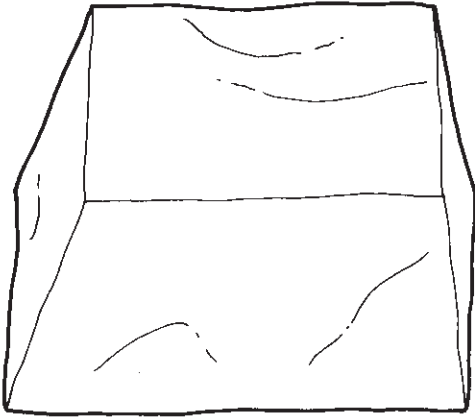

SOFT COVER

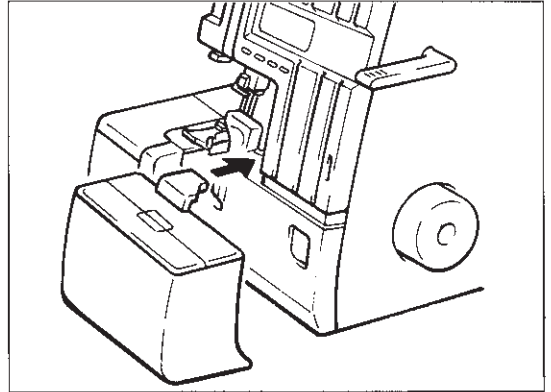

SCRAP CATCHER

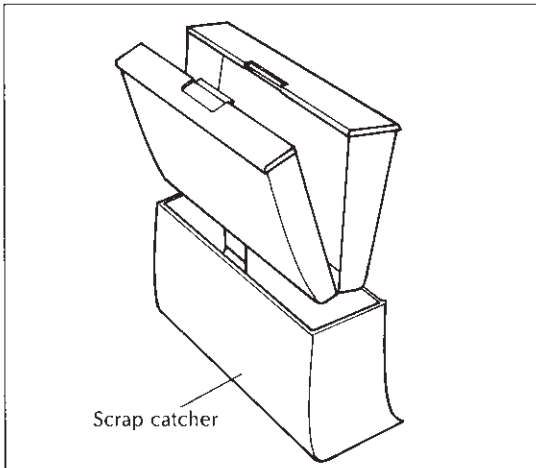

ACCESSORY BOX

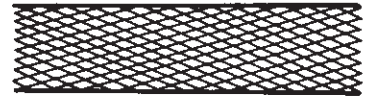

THREAD NET (5)



THREAD SPOOL CAP (5)

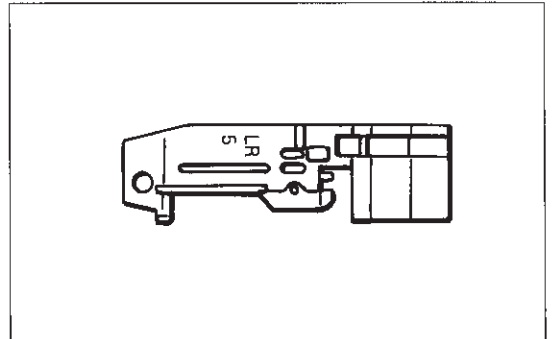
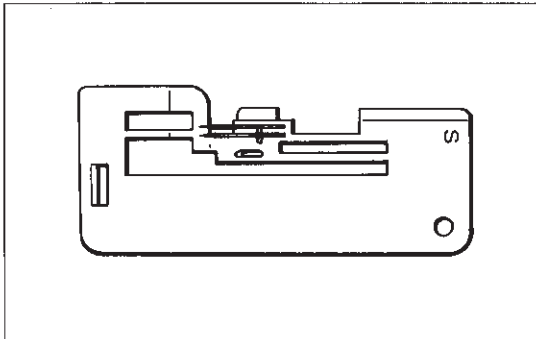

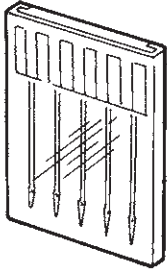

NEEDLE SET

SCHMETZ
130/705H



OILER



TWEEZERS



CLEANING BRUSH



SCREWDRIVER (Large)

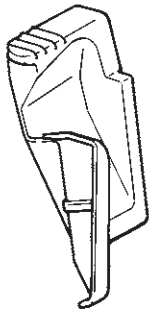

CUTTER COVER I

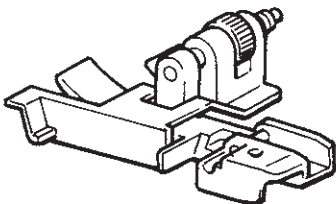

MULTI PURPOSE FOOT



HEXAGON WRENCH

HOW TO USE THE SEWING ADVISOR FUNCTION

Basic operation

All of the operations required for sewing appear as a guide on the display.

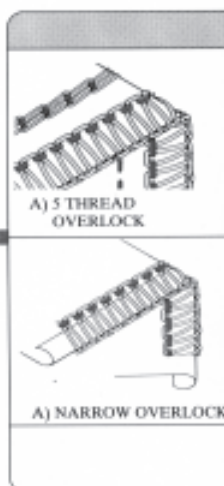
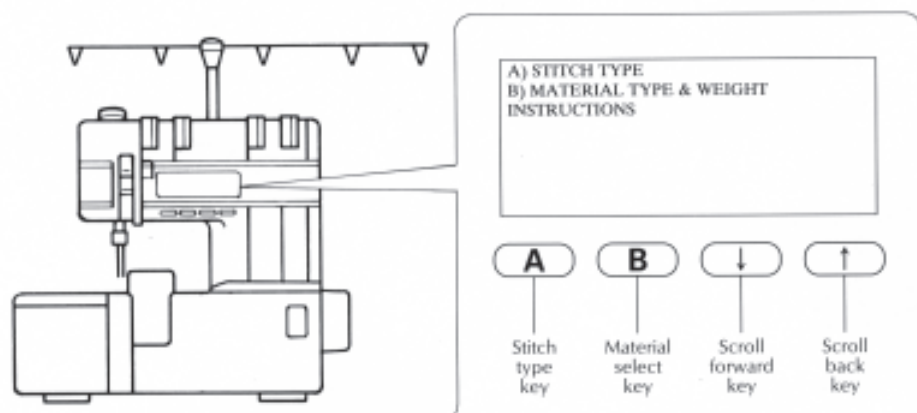

(1) Press key **A** to select the stitch type.



A) 5 THREAD OVERLOCK
B) -----
SELECT BY "A" OR "B" KEY
SETTINGS BY "↓" AND "↑"

If key **A** is pressed continuously, the display will scroll through all stitch types.

(2) Next, press key **B** to select the material type & weight.



A) -----
B) NORMAL MATERIAL
SELECT BY "A" OR "B" KEY
SETTINGS BY "↓" AND "↑"
B) NORMAL (STRETCH)
SELECT BY "A" OR "B" KEY
SETTINGS BY "↓" AND "↑"
B) THIN MATERIAL
SELECT BY "A" OR "B" KEY
SETTINGS BY "↓" AND "↑"

If key **B** is pressed continuously, the display will scroll through all materials.

(3) Press the **↓** key to proceed to the next screen.
Set up according to the instructions which appear on the display.



NEEDLE (REAR) (FRONT)
RIGHT REMOVED
CENTER REMOVED
LEFT 90/14
NEEDLE (REAR)
RIGHT REMOVED
LEFT 80/12
NEEDLE PLATE
S
PRESSER FOOT
LR5 FOOT
THREAD TENSION
4.5.4.4.N
END

If the **↓** key is pressed continuously, the display will return to the screen in step (1) above (for selecting the stitch type).

Press the **↑** key to move back to the previous screen.

Types of stitches (12 types)

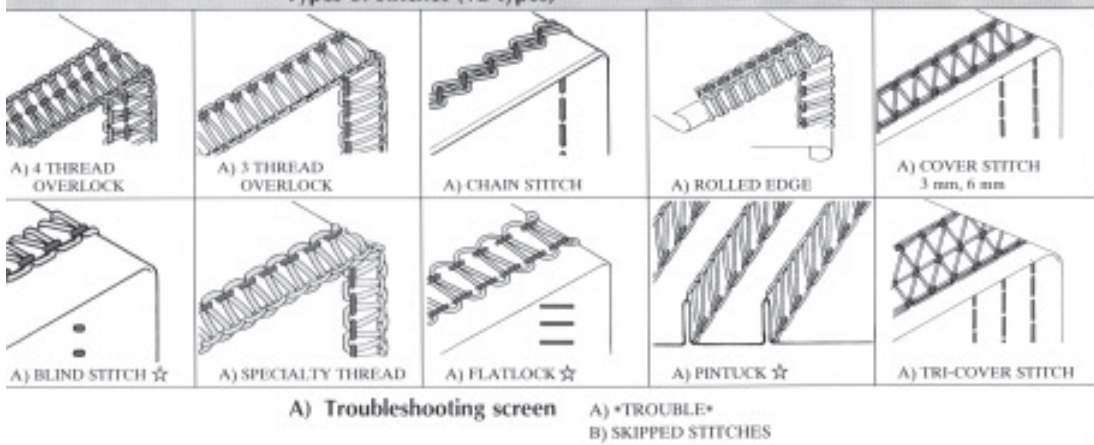

☆ The special blind stitch presser foot can be used.

Explanation of troubleshooting screen

There is a troubleshooting screen at the end of the sewing style screen.

(1) Press the **(A)** key to display the troubleshooting screen.



A) *TROUBLE*
B) SKIPPED STITCHES
SELECT BY "A" OR "B" KEY
SETTINGS BY "!" AND "!"

(2) Next, press the **(B)** key to select the symptoms which correspond to the problem.



A) *TROUBLE*
B) SKIPPED STITCHES
SELECT BY "A" OR "B" KEY
SETTINGS BY "!" AND "!"
B) BAD THREAD TENSION
SELECT BY "A" OR "B" KEY
SETTINGS BY "!" AND "!"
B) THREAD BREAKS
SELECT BY "A" OR "B" KEY
SETTINGS BY "!" AND "!"

If the **(B)** key is pressed continuously, the display will return to the initial item.

(3) Next, press the **(↓)** key to proceed to the next screen.
Operate according to the instructions which appear on the display.



1) IS CORRECT NEEDLE USED?
2) IS NEEDLE INSERTED CORRECTLY?
3) IS THREADING CORRECT?
END

If the **(↓)** key is pressed continuously, the display will return to the screen in step (1) above (initial troubleshooting screen).

Press the **(↑)** key to move back to the previous screen.

● If an error message is displayed on the screen:

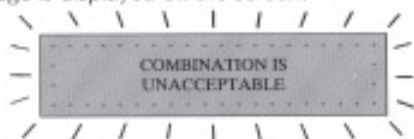

- If the sewing method and material combination are not acceptable, an error message is displayed.
- An error message is also displayed if you try to sew with the presser foot lever raised or the motor locked.

Types of material (6 types)

- B) NORMAL MATERIAL
- B) NORMAL (STRETCH)
- B) THIN MATERIAL
- B) THIN (STRETCH)
- B) THICK MATERIAL
- B) THICK (STRETCH)

Trouble Symptoms

- B) SKIPPED STITCHES
- B) BAD THREAD TENSION
- B) THREAD BREAKS
- B) PUCKERING-VERTICAL
- B) PUCKERING-SIDWAYS
- B) MATERIAL STRETCH
- B) DOES NOT FEED
- B) NEEDLE BREAKS
- B) MATERIAL SLIPPING
- B) MACHINE IS NOISY

SETTING UP YOUR MACHINE

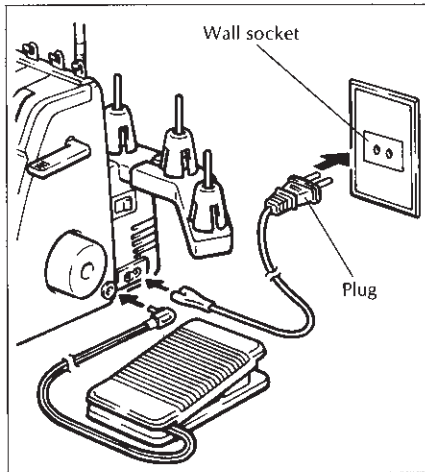

Connecting plugs

When the machine is not in use, disconnect the plug of the power cord from the wall socket.

Motor

- * The maximum operating speed of this sewing machine is 1,300 to 1,500 stitches per minute, which is quite fast compared to the operating speed of 600 to 800 stitches per minute for the ordinary home sewing machine. It should be noted that the motor of this sewing machine turns in the same direction as the motor in an ordinary home sewing machine.
- * The bearings in the motor are made of special, sintered oil-impregnated alloy mounted in oil-soaked felt to withstand long hours of continuous operation.
- * Continuous operation of the sewing machine will slightly increase the temperature of the motor, but this will in no way affect the performance.
The motor and foot control are equipped with ventilating holes located at the right back corner of the machine, which must not be covered with cloth or paper during use.
- * When the motor is running, sparks may be seen through the ventilating hole in the motor bracket on the side opposite the handwheel. These sparks are produced by the carbon brushes and the commutator, and are of no significance.

Safety regulation for domestic sewing machines in conformity with "CEE Publication No.10, Part II, Section C, Article 7.1". When the machine is not in use, or when threading, replacing needle or light bulb, the machine must be disconnected from the power supply by removing the plug from the wall socket. Use bulbs designed for max 8V/2.4W. The machine has an interference suppressor for radio and television, complying with Directive No.87/308 E.E.C. and C.I.S.P.R.

NEEDLE

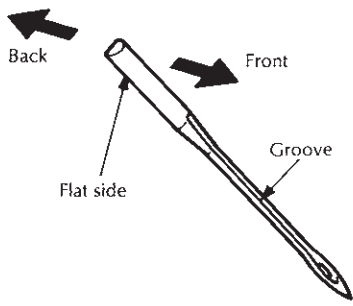

How to check the needle

Place a needle on its flat side and check the space to see if it is parallel or not.

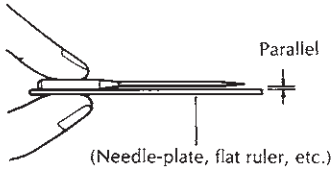

* Use SCHMETZ 130/705H needles.

※As for proper size of needle for each material, refer to page 39 "RELATIONSHIP BETWEEN SEWING MATERIAL, THREAD AND NEEDLE".

CAUTION!

* Use only one, two or three needles at one time.

* Do not use with all needles installed at the same time.

* If setting the left (LN) and right (RN) needles at the same time, the left needle will be higher.

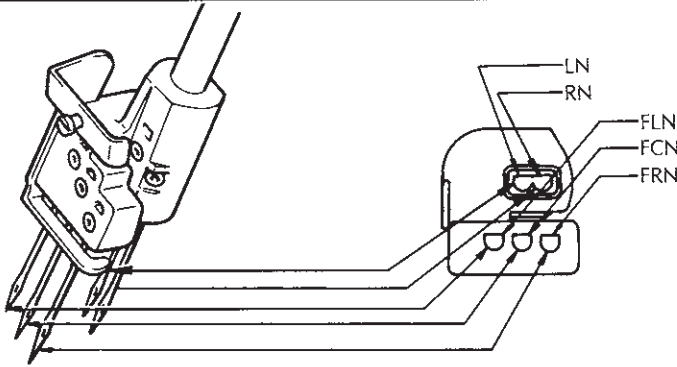

FLN: Front left needle
FCN: Front center needle
FRN: Front right needle
LN: Left needle
RN: Right needle

When front needles are inserted correctly you can see the top of the needle in the window above each needle position.

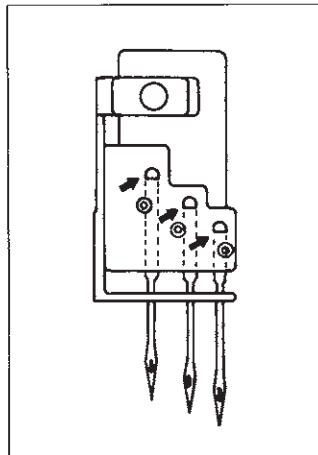

NEEDLE

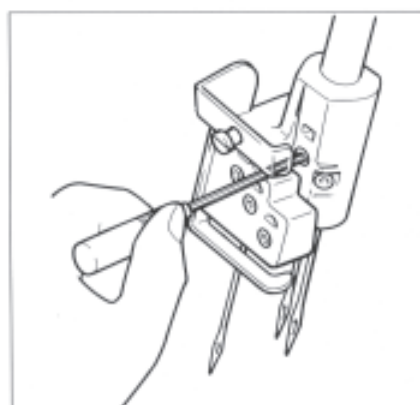
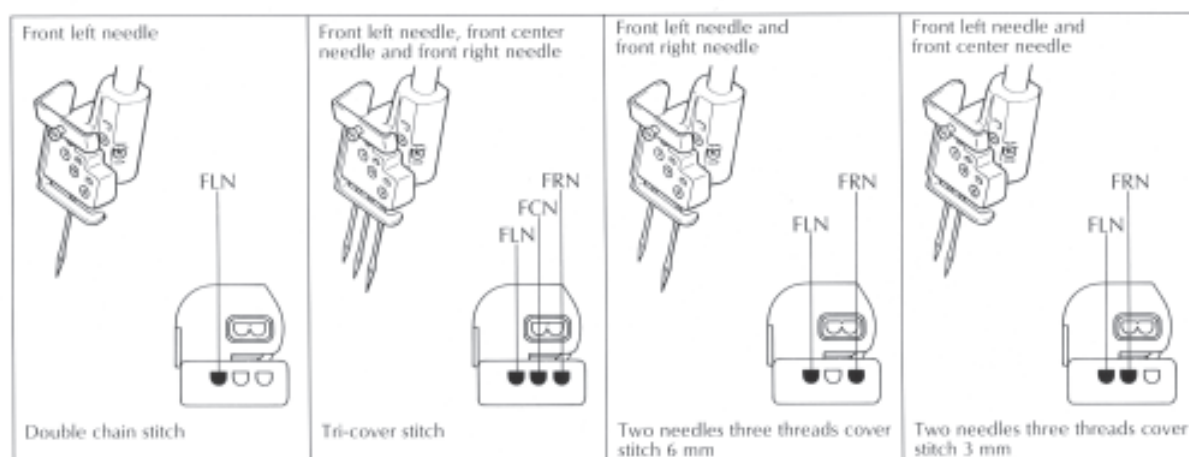
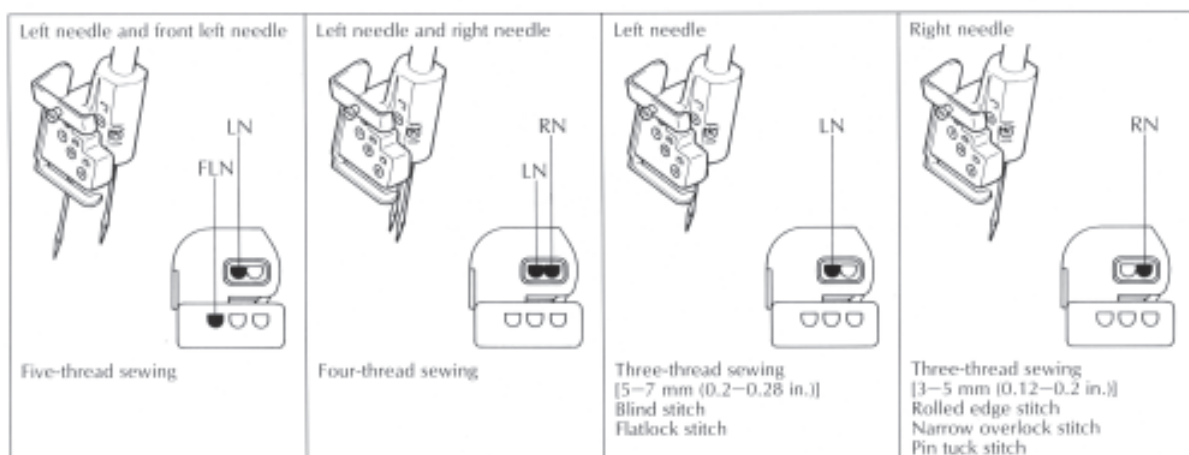

To remove the needle

- 1) Turn the main power switch to off.
- 2) Turn the handwheel counterclockwise by hand until the needle is in its highest position.
- 3) Loosen the needle set screw with allenwrench and remove the needle.

IMPORTANT!

Lightly tighten the screw at the unused needle position, so it does not fall out while sewing.

NOTE

You will never sew with the needles in place as illustrated.

To insert the needle

- 1) Turn the main power switch to off.
- 2) Turn the handwheel until the needle bar is in its highest position.
- 3) Hold the needle with its flat side away from you and **insert it as far as it goes**.
- 4) Tighten the needle set screw securely.
- 5) If a needle does not go up all the way it may be necessary to loosen the adjacent needle screw.

Position of needle when using the cover stitch function

Refer to the section Using Cover stitch Function on page 19 for details.

THREADING

Raise the thread holder stand and position it so that the thread holders are directly above the spool supports.

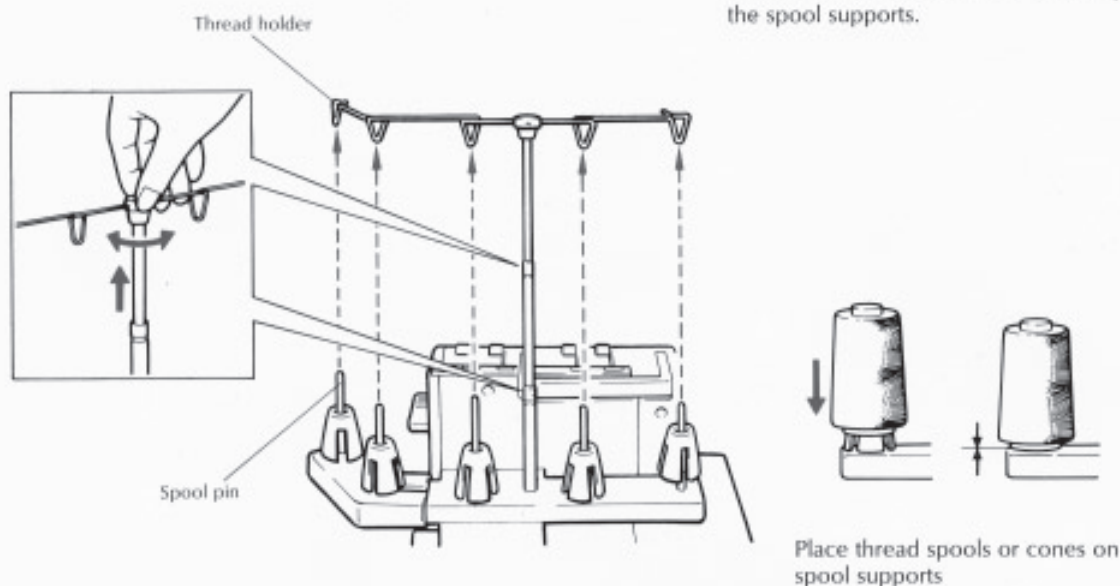

NOTE

HOW TO USE THREAD SPOOL CAP AND NET

THREAD SPOOL CAP

When you use a standard thread spool, use the thread spool cap as illustrated.

NET

If you are sewing with loosely spun nylon or decorative thread, we recommend that you cover the spool with the net supplied to prevent the thread from slipping off the spool. Adapt the net to the shape of the spool as illustrated.

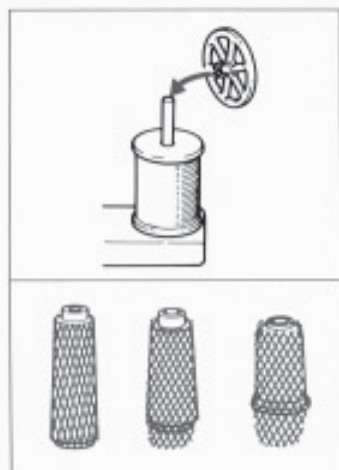



Before threading...

- 1) Turn off the main power switch for safety.
 ※Turn on the main power switch when referring to the LCD in order to thread the needle, but disconnect the foot control from the machine as a safety measure.

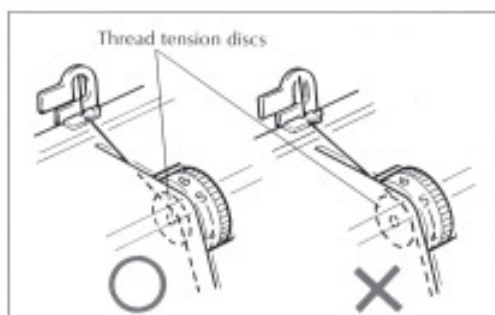

- 2) Raise the presser foot by using presser foot lever.
 When the presser foot is raised, the two thread tension discs are released so that thread passes freely between them. Otherwise thread tension may not be correct.

IMPORTANT!

When threading the needle, always be sure to lift the presser foot lever, and also take care to thread in the proper order.

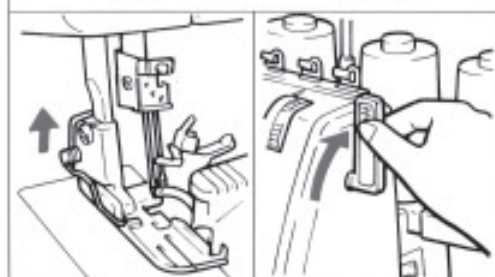

- 3) Set the needle bar in its highest position by turning the handwheel toward you.

Turn the handwheel to find the easiest position for threading, and then thread the upper looper thread, lower looper thread, right needle thread and then the left needle thread or double chain stitch needle thread in that order.

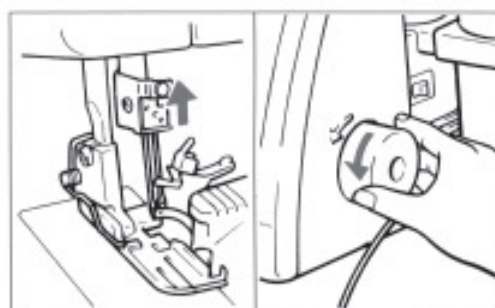

NOTE

Threading order

Thread in the following order:

- 1) Upper looper thread (green)
- 2) Lower looper thread (blue)
- 3) Double chain stitch looper thread (purple) in case of 5 thread stitch or double chain stitch (Use lower looper tension to brown guides on double chain)
- 4) Right needle thread (red)
- 5) Left needle thread or double chain needle thread (yellow)

THREADING

Threading upper looper (green)

Run the thread in the sequence illustrated as marked by green dots.

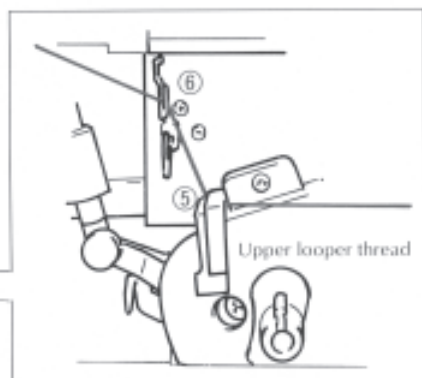
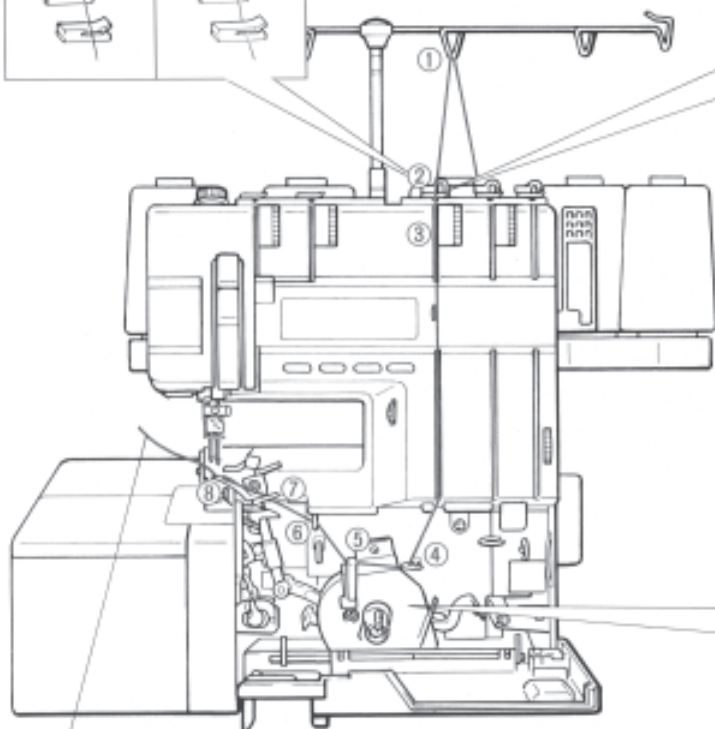
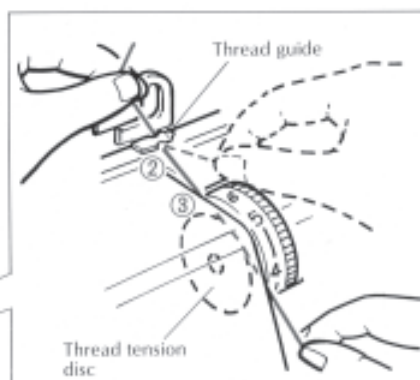
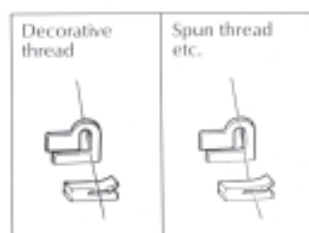

Pull out the thread about 15 cm (6 in.) away from you.

NOTE

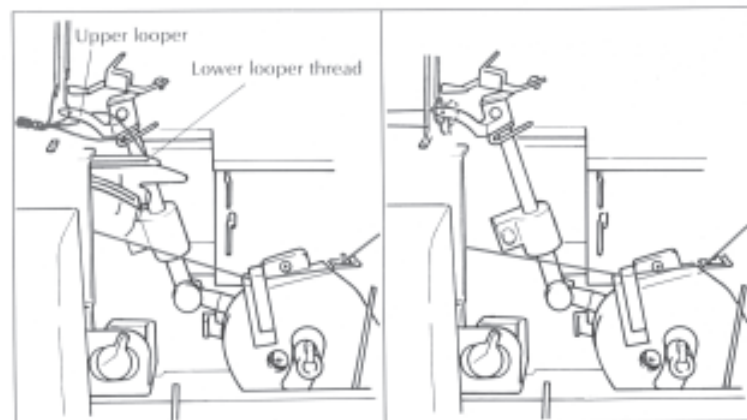

If upper looper thread breaks during sewing

If the lower looper thread hangs on upper looper. Lower the upper looper by turning the handwheel and take the lower looper thread off upper looper. Then re-thread the upper looper.

Threading lower looper (blue)

Run the thread in the sequence illustrated as marked on the machine with blue dots.

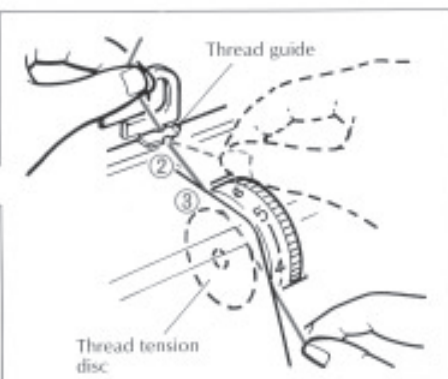
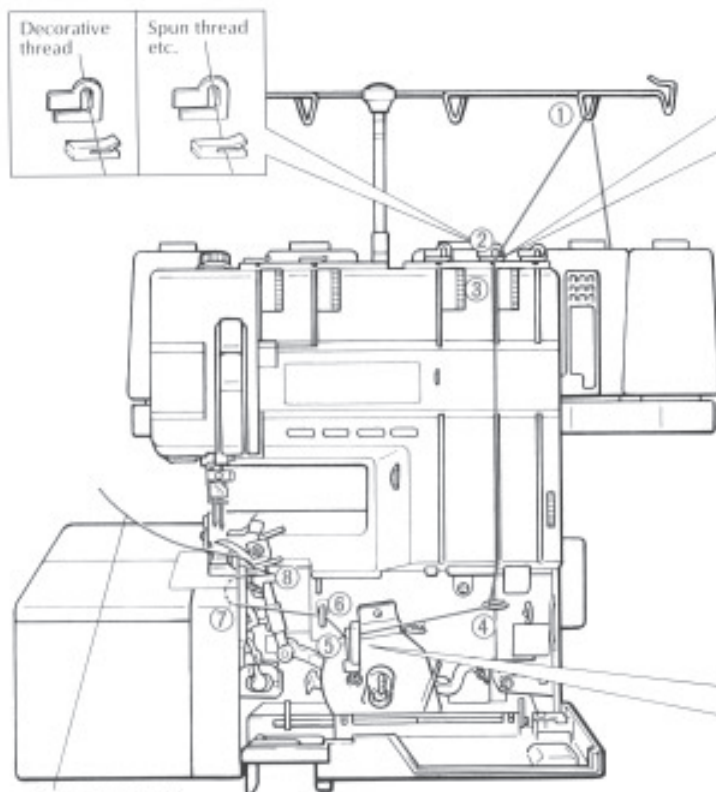

NOTE

If lower looper thread breaks during sewing
Before re-threading the lower looper, **cut and remove both needle threads.** Then re-thread the lower looper. Needles must be threaded after the lower looper.

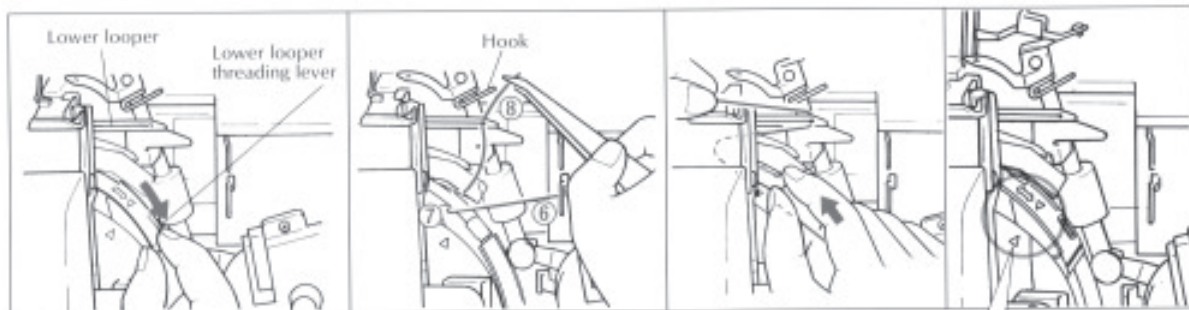

Easy threading lever

- 1) Pull down the lower looper threading lever to reveal the thread well.
- 2) Thread the lower looper eye first then position the thread around the end of the lower looper threading lever.
- 3) Push the lower looper threading lever back to the left while holding the end of the thread.

CAUTION!

When returning the lower looper threading lever, always make sure that the two blue triangle marks (▼ & ▲) meet each other as shown in the illustration.

THREADING

Threading the double chain stitch looper thread (purple)

Run the thread in the sequence illustrated.

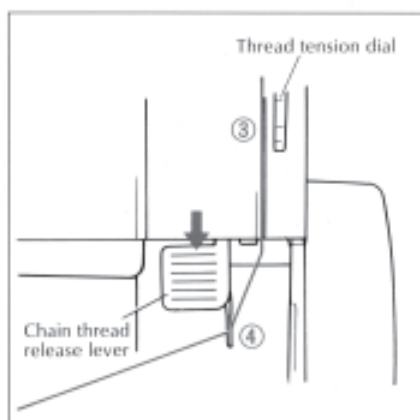
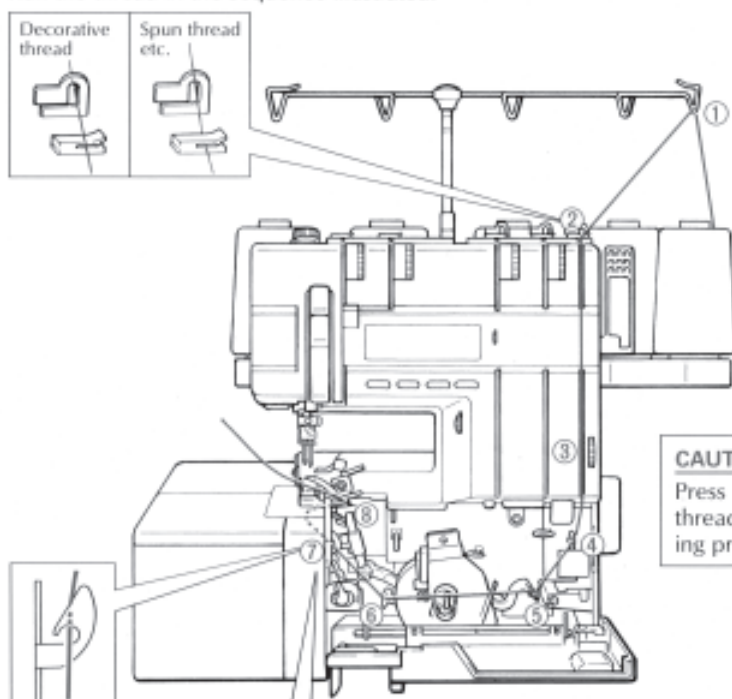

CAUTION!

Press the release lever at step 4 of the chain thread (double chain stitch looper thread) threading process to seat thread properly.

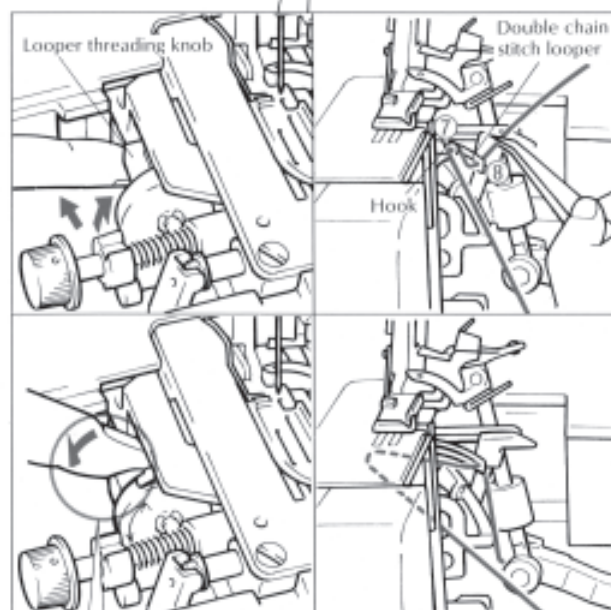

Using the double chain stitch looper threading mechanism

- 1) Open the side cover to the left.
- 2) Push and lift up the looper threading knob.
- 3) After threading the thread onto the double chain stitch looper threading hook, thread it through the double chain stitch looper eye.
- 4) While holding the end of the thread, return the looper threading knob to its original position.
- 5) Close the side cover.



Threading the thread on the double chain stitch looper hook

NOTE

Snap off the standard needle plate and replace with cover stitch needle plate C.

CAUTION!

When returning the looper threading knob to its original position, make sure that the ■ mark is aligned with the ▼ mark.

THREADING NEEDLES

IMPORTANT!

Thread the needles after threading upper looper and lower looper.
First raise the presser foot lever, and then thread the needle threads in the order shown in the illustration.

1) Right needle thread (red)

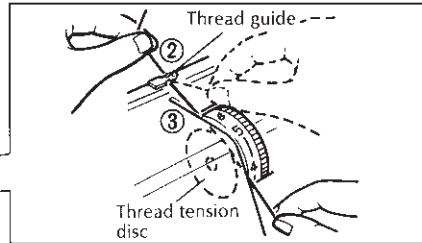
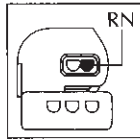
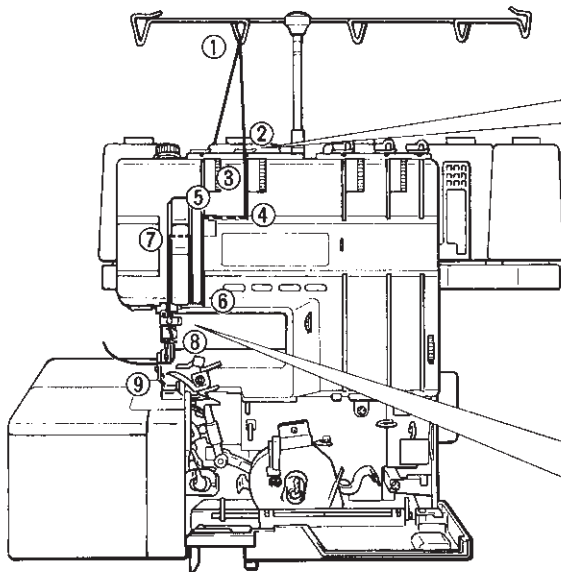

CAUTION!

Pass the thread along the right side of the needle thread separator.

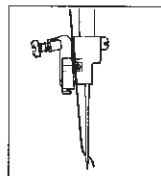

Not through front needle guide

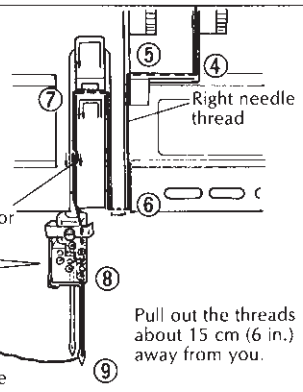

Pull out the threads about 15 cm (6 in.) away from you.

IMPORTANT!

Be sure to thread the double chain stitch looper before threading the needles.

2) Threading the left needle thread (yellow)

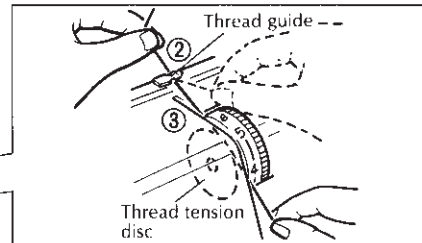
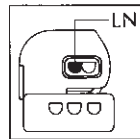
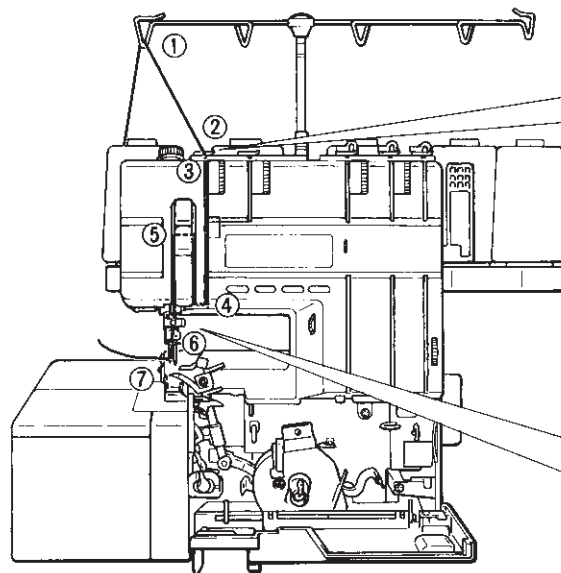

CAUTION!

Pass the thread along the left side of the needle thread separator.

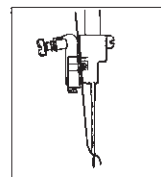

Not through front needle guide

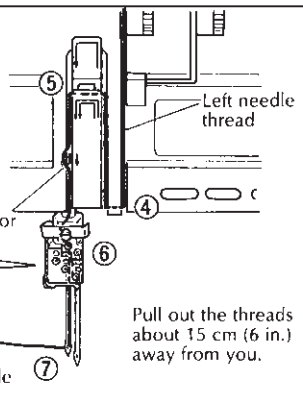

Pull out the threads about 15 cm (6 in.) away from you.

THREADING NEEDLES

3) Double chain stitch needle thread (yellow)

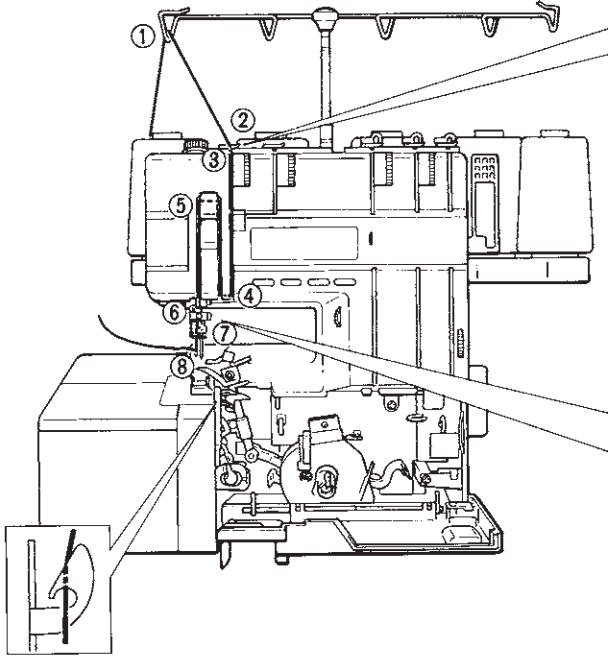
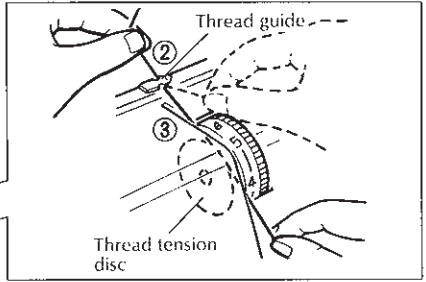
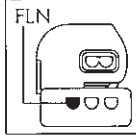

CAUTION!

Pass the thread along the left side of the needle thread separator.

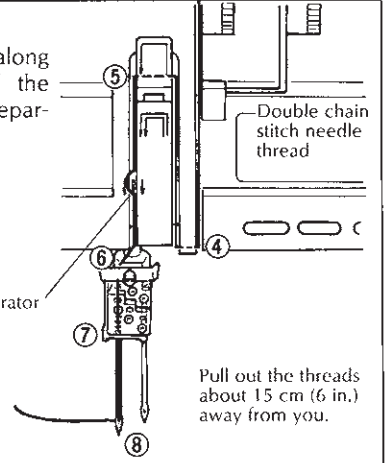

USING THE COVER STITCH FUNCTION

Replacing the presser foot

Snap on the cover stitch presser foot (LC) for 3 mm, 6 mm or tri-cover stitch.

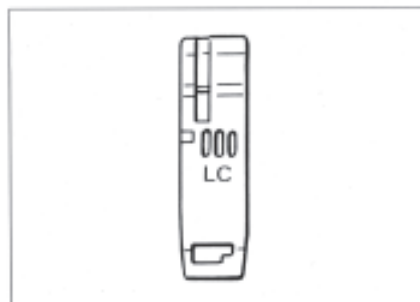

1. Remove needles

2. Changing the needle plate

When sewing a 6 mm, 3 mm, tri-cover stitch or double chain stitch, replace the needle plate with the cover stitch needle plate (C). The stitch finger and the cutter must be moved away before changing the needle plate and the width dial set at R.

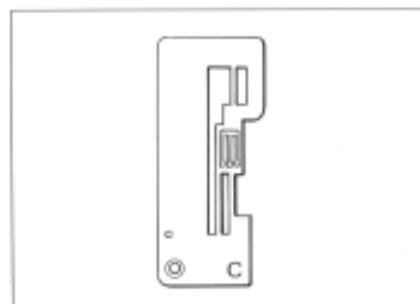

NOTE

If 3 mm, 6 mm or tri-cover stitch is selected on the Sewing Advisor the sewing speed is automatically reduced.

Replacement of needle plate

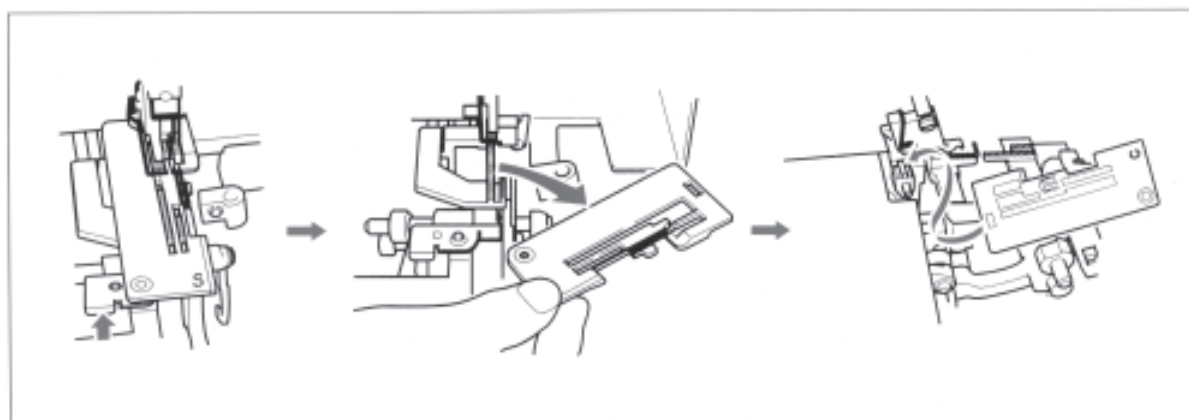

USING THE COVER STITCH FUNCTION

TRI-COVER STITCH (THREE NEEDLES FOUR THREADS COVER STITCH)

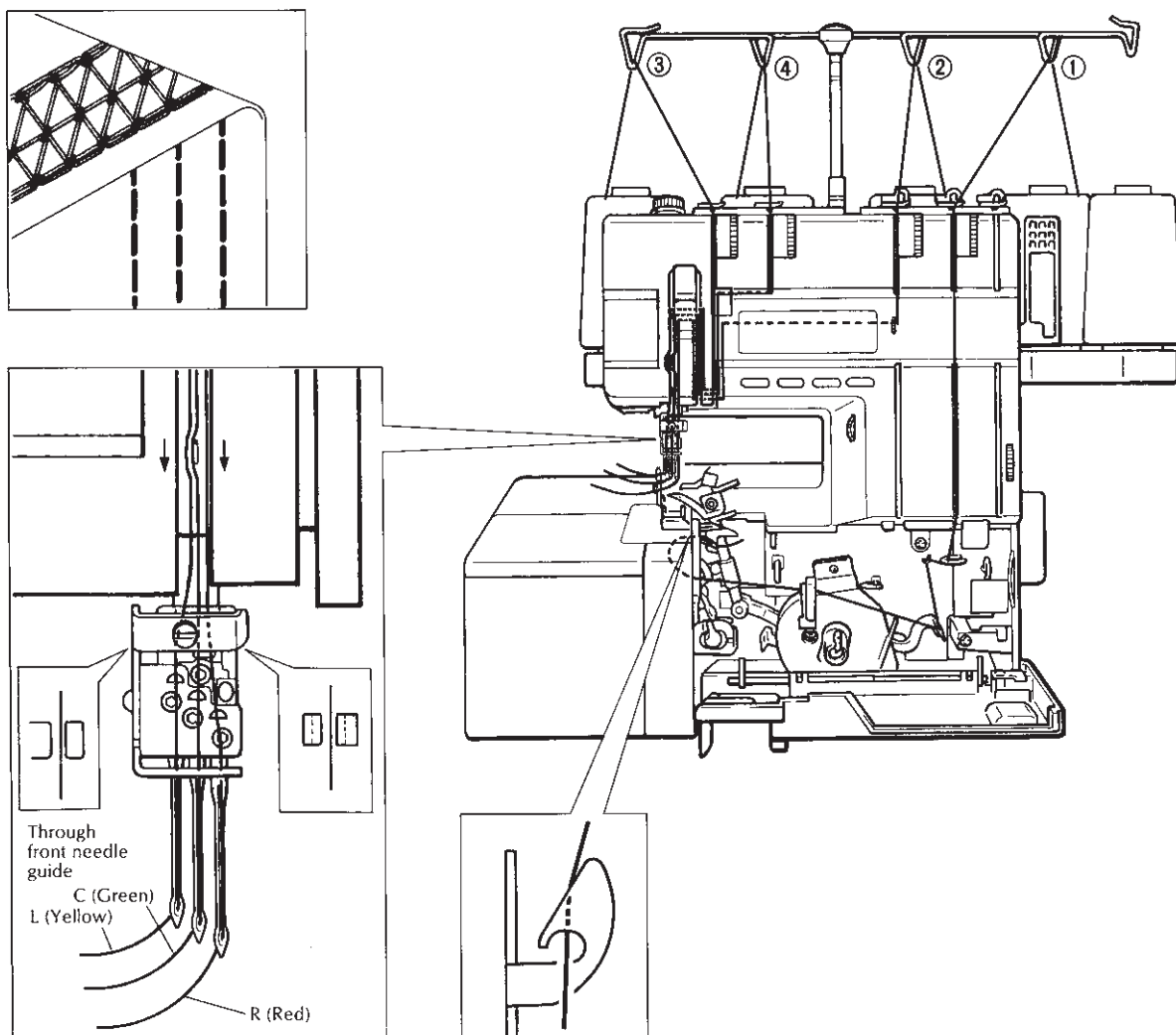

Inserting the needles

Needle hole diagram

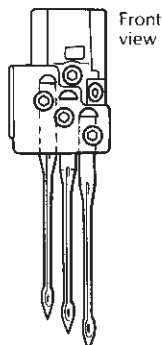
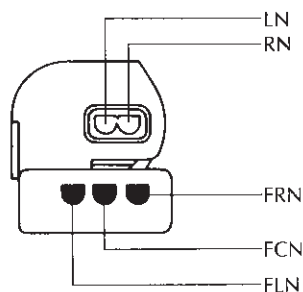

When sewing a tri-cover stitch, insert the needle into the FLN, FCN and FRN positions.

* SCHMETZ 130/705H needle (SCHMETZ standard #90) should be used.

TWO NEEDLES THREE THREADS COVER STITCH

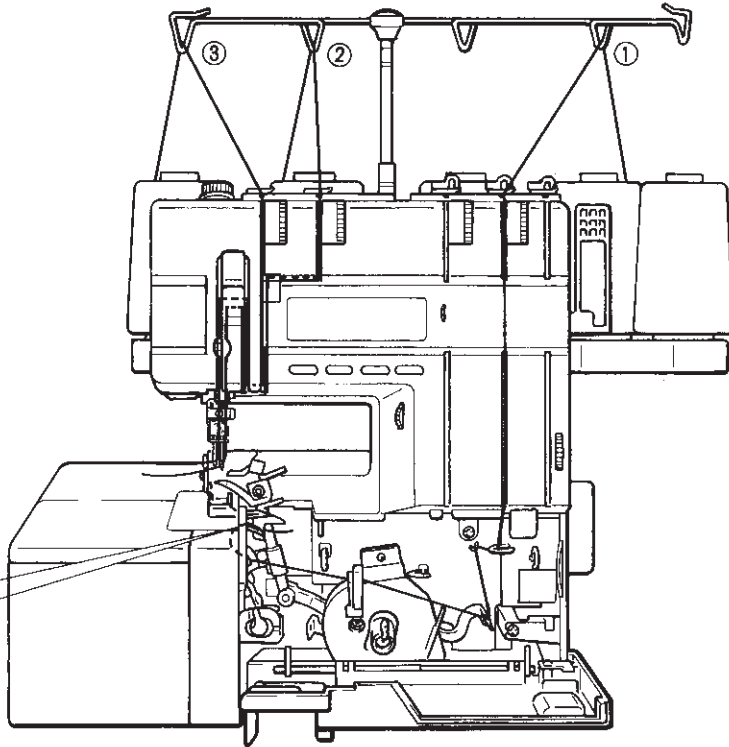
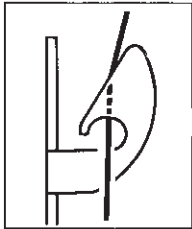
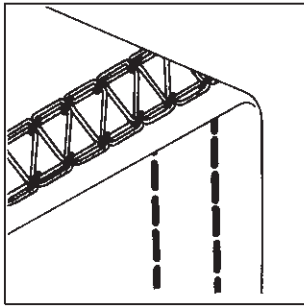

Inserting the needles

When sewing a 6-mm cover stitch, insert the needles into the FRN and FLN positions.

When sewing with a 3-mm stitch width, insert the needles into the FCN and FLN positions.

Needle hole diagram

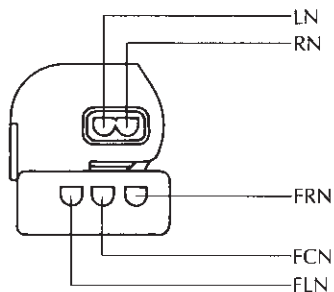

When sewing with a 6-mm cover stitch

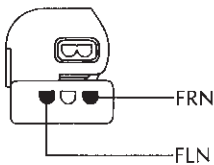
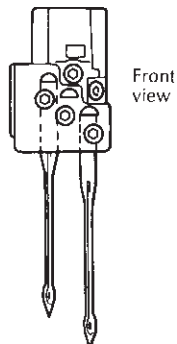

When sewing with a 3-mm cover stitch

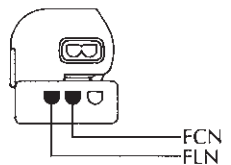
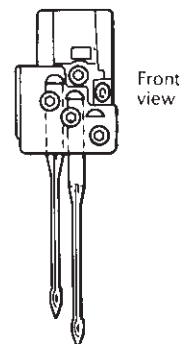

* SCHMETZ 130/705H needle (SCHMETZ standard #90) should be used.

THREADING FOR COVER STITCH

Looper

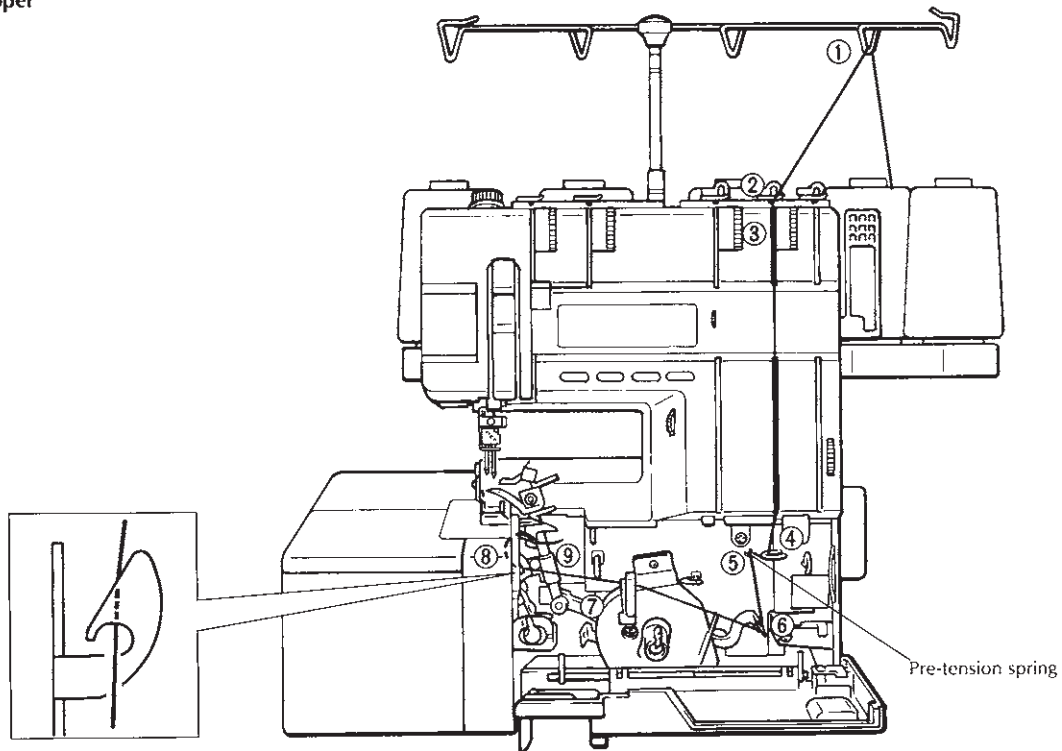

Thread the looper thread for the cover stitch. Pass the thread through the same tension path as for the lower-looper and then follow the path for the double chain stitch looper (brown path). Open the side cover to the left. Push and lift up the chain stitch looper threading knob. After threading the thread on to the chain stitch threading hook, thread it through the chain stitch looper. While holding the end of the thread, return the looper threading knob down to its original position. Close the cover.

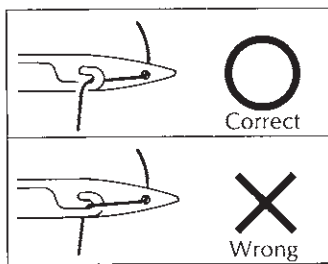
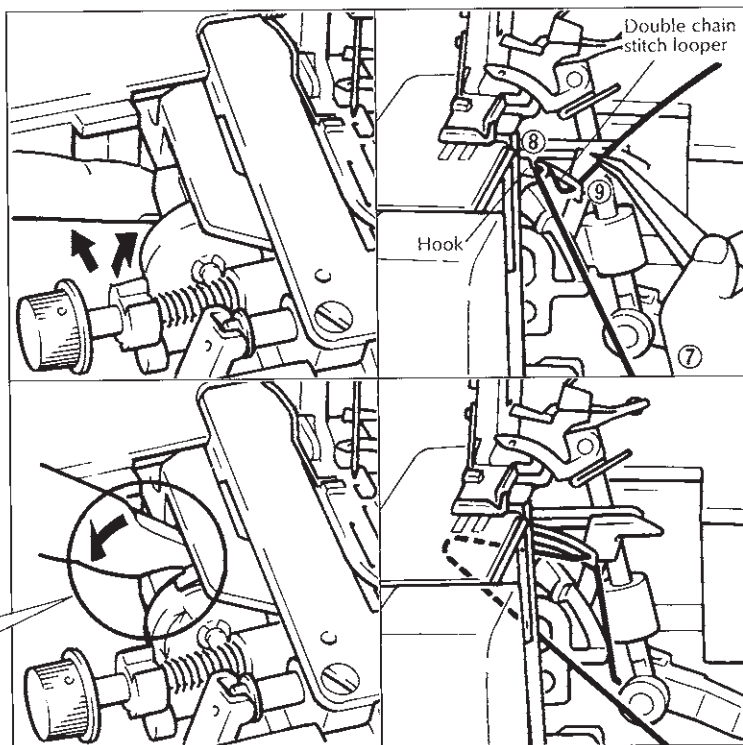

CAUTION!
When returning the looper threading knob to its original position, make sure that the ■ mark is aligned with the ▼ mark.

Needle thread-front right (FRN) and front center (FCN)

- When sewing with a 6-mm stitch width and tri-cover stitch
Pass the thread along the same thread path as for the right needle thread and then through Front Right needle (FRN).
- When sewing with a 3-mm stitch width
Pass the thread along the same thread path as for the right needle thread and then through Front Center needle (FCN).

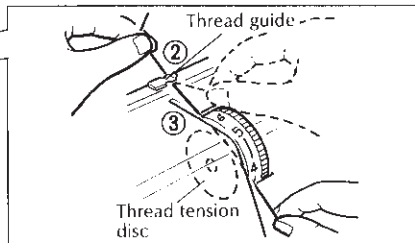
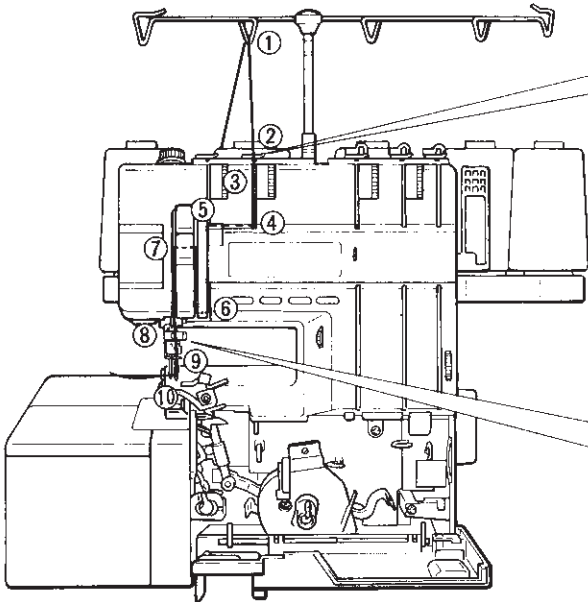
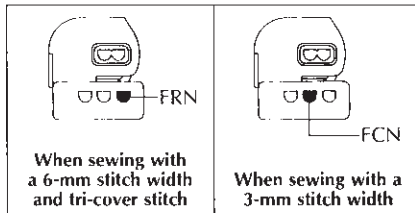

CAUTION!
Pass the thread along the right side of the needle thread separator.

Right needle thread

Needle thread separator

Refer to page 19.

Pull out the threads about 15 cm (6 in.) away from you.

Needle thread front left (FLN)

- Pass the thread along the same thread path as for the front left needle thread and then through Front Left needle.

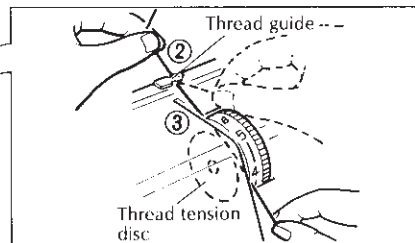
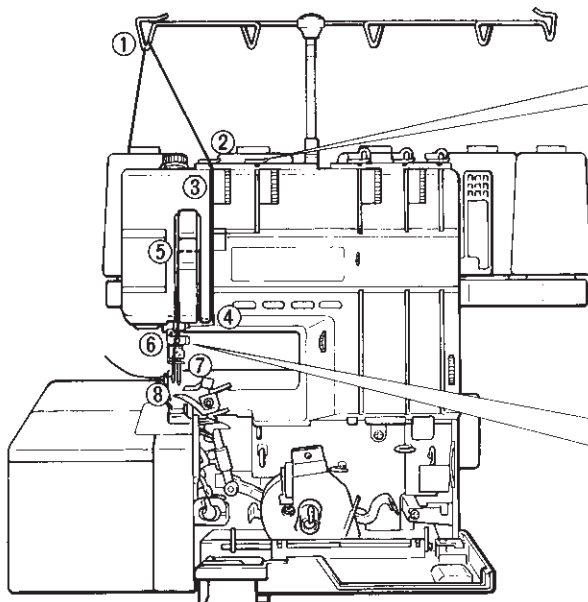
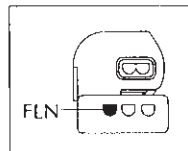

CAUTION!
Pass the thread along the left side of the needle thread separator.

Left needle thread

Needle thread separator

Refer to page 19.

Pull out the threads about 15 cm (6 in.) away from you.

THREADING FOR COVER STITCH

ACTUAL EXAMPLES OF TWO NEEDLES THREE THREADS COVER STITCH SEWING

Needle thread front center (FCN)

When sewing with a tri-cover stitch

Pass the thread along the same thread path as for the front center needle and then through Front Center needle.

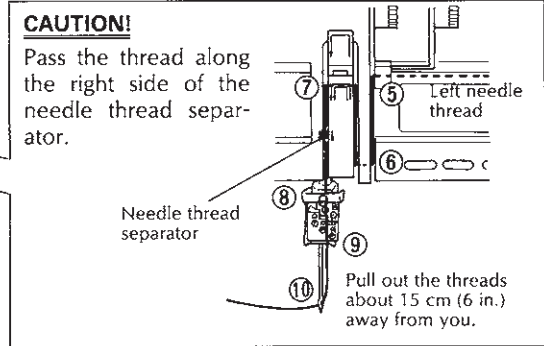
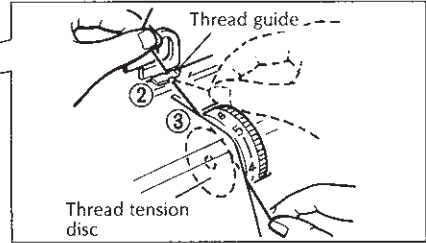
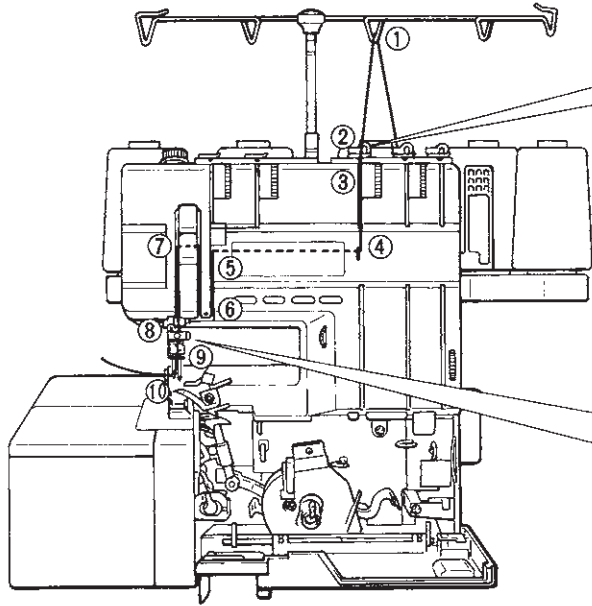
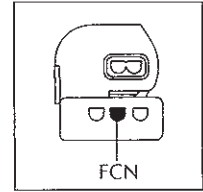

Actual examples of two needles three threads cover stitch sewing

1) Hems of T-shirts
(Simple Stitch)

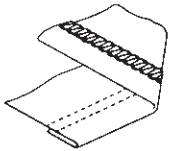

2) Stitches
(Top Stitched Seams/Ribbing/Yokes)

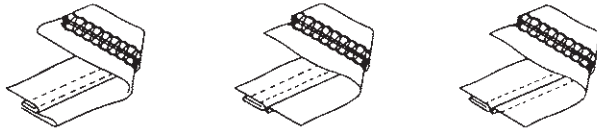

3) Attaching tape (edges of collars, etc.)
(Binding)

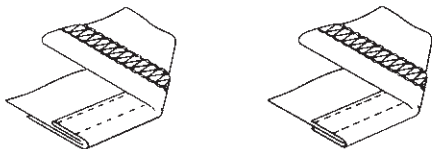

4) Decorative stitching
(Decorative Stitching)

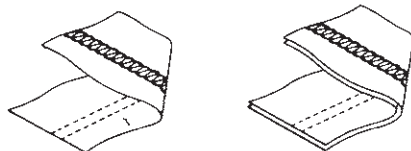

ACTUAL EXAMPLES OF THREE-NEEDLE FOUR-THREADS COVER STITCH SEWING

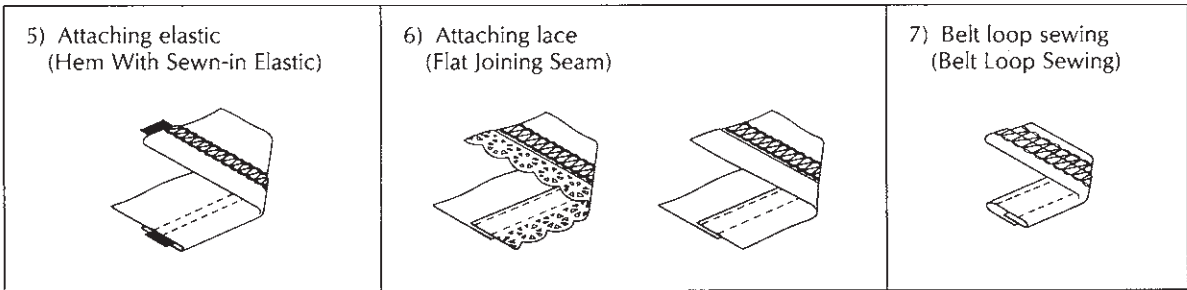

(3-mm Width Cover Stitch)

3-mm width cover stitches are ideal for sewing thin knitted material and normal material.

- After threading, be sure to insert the material under the foot and the needles before starting to sew.
- When the end is reached, sew a chaining-off stitch for about 5 cm while lightly pulling the material, then trim the thread.
- When sewing cylindrical objects, sew overlapping the beginning by about 1 cm. Hand turn, the handwheel clockwise one half to 3/4 turn while lightly pulling fabric away to release needle thread from chain stitch looper. Pull fabric away and trim threads.

Actual examples of three-needle four-threads cover stitch sewing

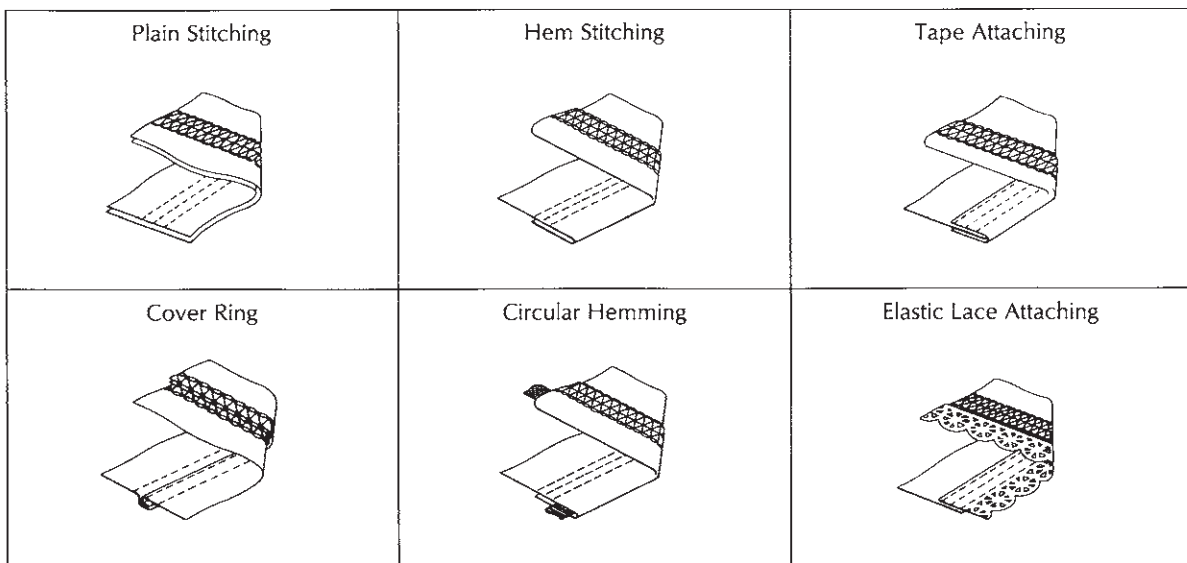

Fagehing

STITCH SELECTION

This machine can form eight kinds of stitches in simple steps as follows:

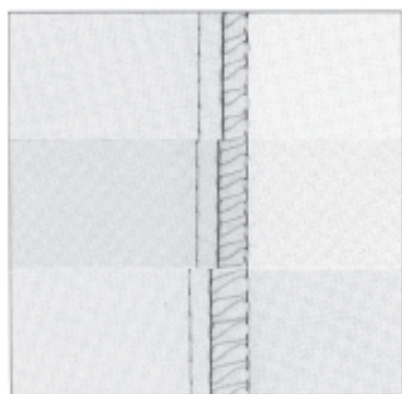

1. FIVE-THREAD OVERLOCK STITCH

[Stitch width — 6, 7, 8 mm (0.24, 0.28, 0.31 in.)]

Use five threads to produce overlock seams for medium-thick material.

Use: For overlock stitching of sewing suits, blouses, draperies, jeans, etc.

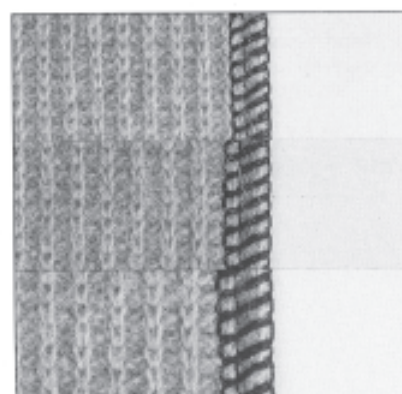

2. FOUR-THREAD OVERLOCK STITCH

[Stitch width — 5, 6, 7 mm (0.2, 0.24, 0.28 in.)]

Use four threads (UL, LL, RN, LN) for producing four-thread overlock stitches on most woven and knit fabrics.

Use: Ideal for overlock sewing of woven and knitted garments

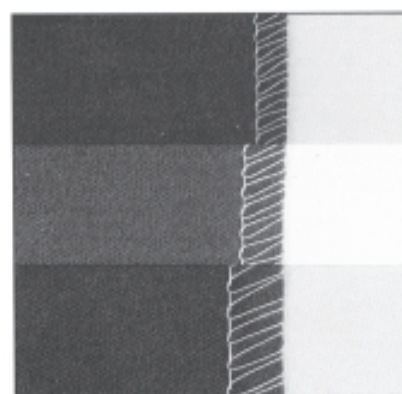

3. THREE-THREAD WIDE OVERLOCK STITCH

[Stitch width — 5, 6, 7 mm (0.2, 0.24, 0.28 in.)]

Use the UL, LL & LN for producing 5, 6, or 7 mm seams.

Remove the right needle when sewing this overlock stitch.

Use: For seam finishing and sewing with decorative threads.

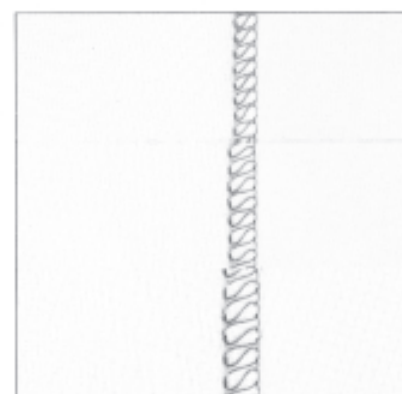

4. THREE-THREAD NARROW OVERLOCK STITCH

[Stitch width — 3, 4, 5 mm (0.12, 0.16, 0.2 in.)]

Use the UL, LL, & RN for producing 3, 4 and 5 mm seams which will sew all kinds of materials.

Remove the left needle when sewing this overlock stitch.

Use: For seam finishing and sewing with decorative threads.

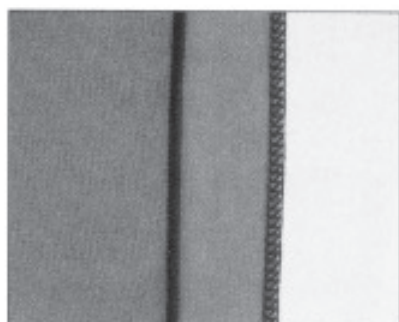

5. **NARROW OVERLOCK STITCH/ROLLED EDGE STITCH**
 Use three threads and the right needle. (Refer to "NARROW OVERLOCK STITCH/ROLLED EDGE STITCH" on pages 44–45.) (Refer to "NEEDLE" on pages 8–10.)
 Use: For finishing napkin edges, hemming, and pintucks.

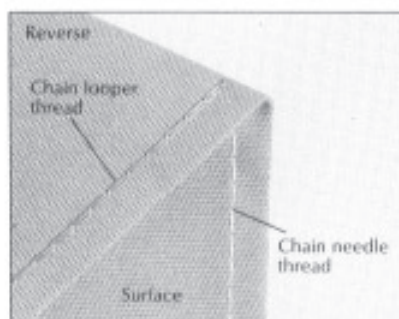

6. **DOUBLE CHAIN STITCH SEWING**
 Use two threads. The chain stitch looper thread and the double chain stitch needle thread. This is ideal for regular stitching for which overlock is not necessary and decorative stitching. (Refer to "SETTING FOR DOUBLE CHAIN STITCH SEWING" on pages 29–31.)
 Use: For straight stitching, basting and decorative chain stitch.

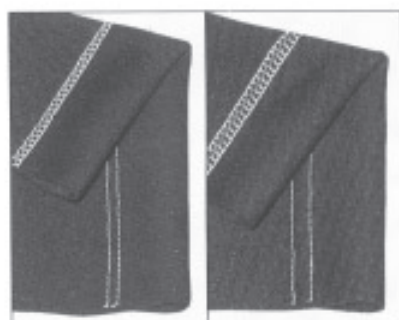

3 mm

6 mm

7. **TWO NEEDLES THREE THREADS COVER STITCH**
 Use three threads, two front needles and the chain stitch looper thread to sew a 3 mm or 6 mm cover stitch.
 Use: Ideal for hemming knits and wovens and for decorative stitching.

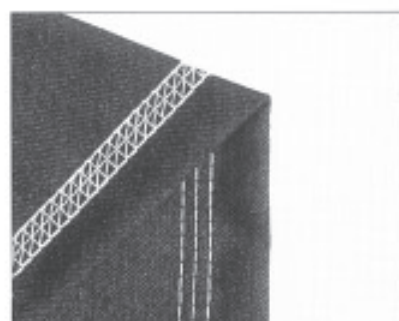

8. **TRI-COVER STITCH**
 (Three needles four threads cover stitch)
 Use four threads three front needles and the chain stitch looper thread to sew a 6 mm cover stitch.
 Use: Ideal for hemming knits and for decorative stitching.

THREAD SETTING FOR VARIOUS STITCHES

FIVE-THREAD OVERLOCK STITCH

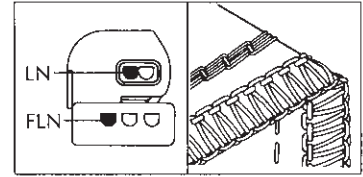
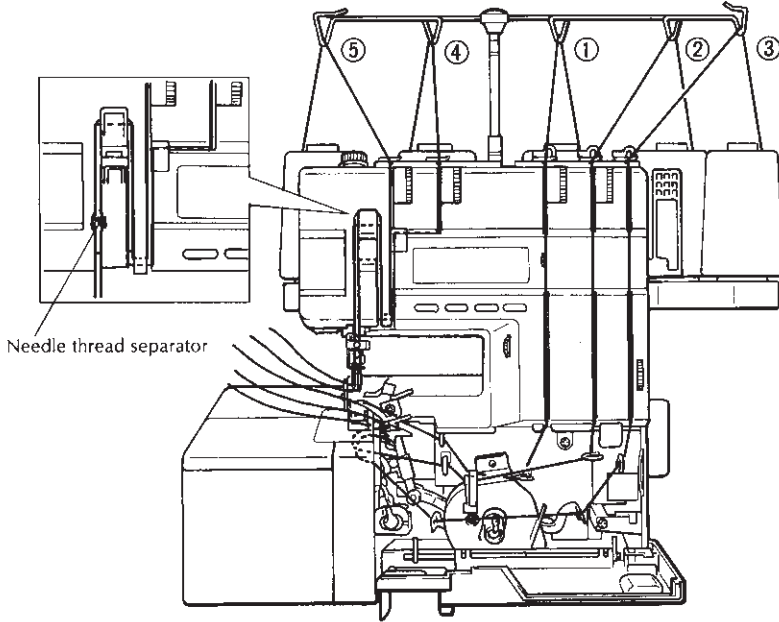

Thread in the following order:

- 1) Upper looper thread (green)
- 2) Lower looper thread (blue)
- 3) Double chain stitch looper thread (purple)
- 4) Left needle thread (red)
- 5) Double chain needle thread (yellow)

FOUR-THREAD OVERLOCK STITCH

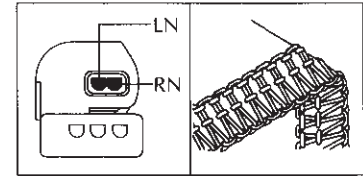
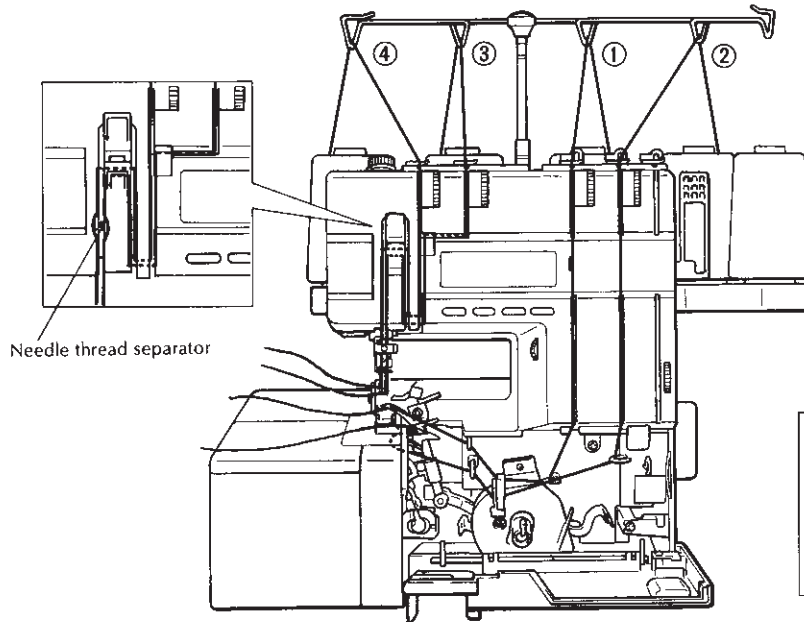

Thread in the following order:

- 1) Upper looper thread (green)
- 2) Lower looper thread (blue)
- 3) Right needle thread (red)
- 4) Left needle thread (yellow)

IMPORTANT!

If the double chain stitch looper thread and the double chain stitch needle thread have been threaded, cut and remove the threads before four-thread overlock stitch threading.

THREE-THREAD OVERLOCK STITCH

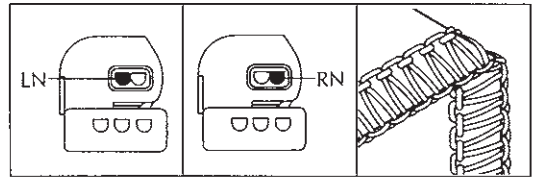
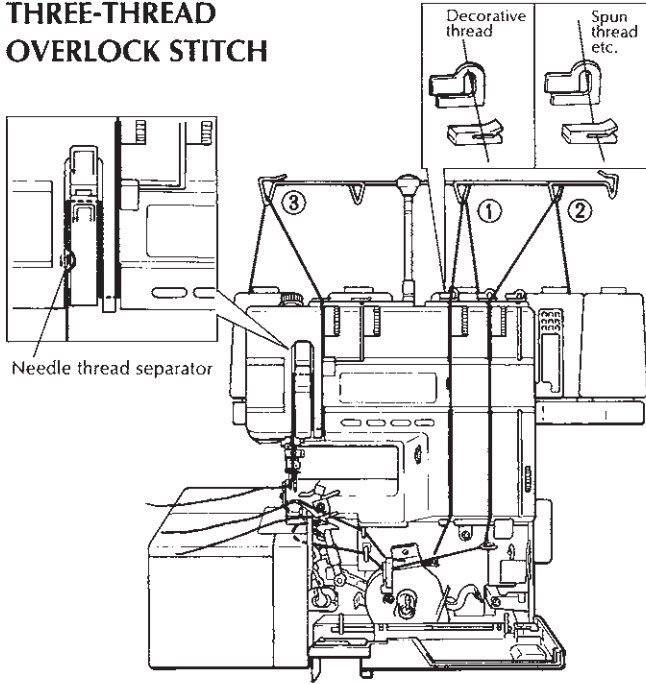

Thread in the following order:

- 1) Upper looper thread (green)
- 2) Lower looper thread (blue)
- 3) Left needle thread for a wide 3 thread (yellow) or right needle thread (red) for a narrow 3 thread

IMPORTANT!

If the double chain stitch looper thread and the double chain stitch needle thread have been threaded, cut and remove the threads before threading for another stitch.

DOUBLE CHAIN STITCH

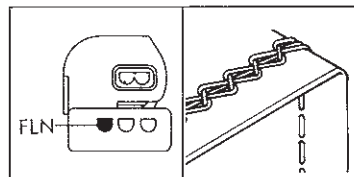
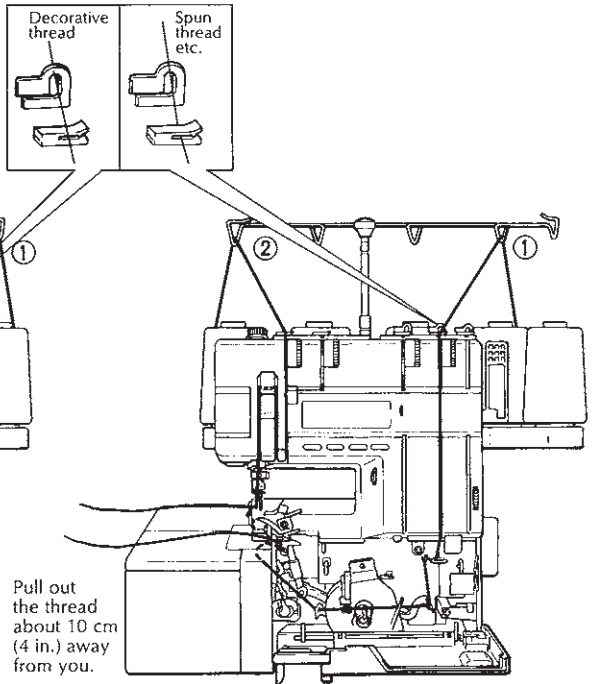
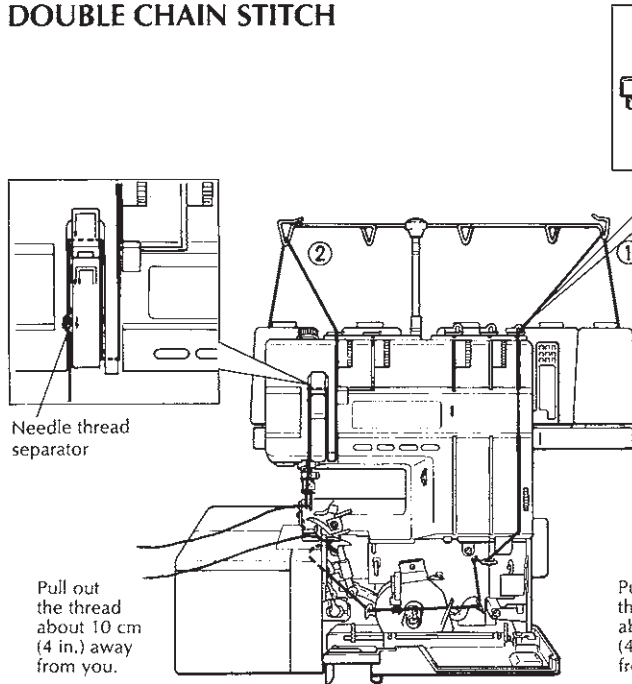

Thread in the following order:

- 1) Double chain stitch looper thread (purple), (brown)
- 2) Double chain needle thread (yellow)

※To use the double chain stitch looper threading mechanism, refer to page 15.

IMPORTANT!

This section deals only with double chain stitch sewing. Accordingly, carry out the operations as described on the following pages.

SETTING FOR DOUBLE CHAIN STITCH SEWING

1. Retracting the upper looper for chain stitch sewing

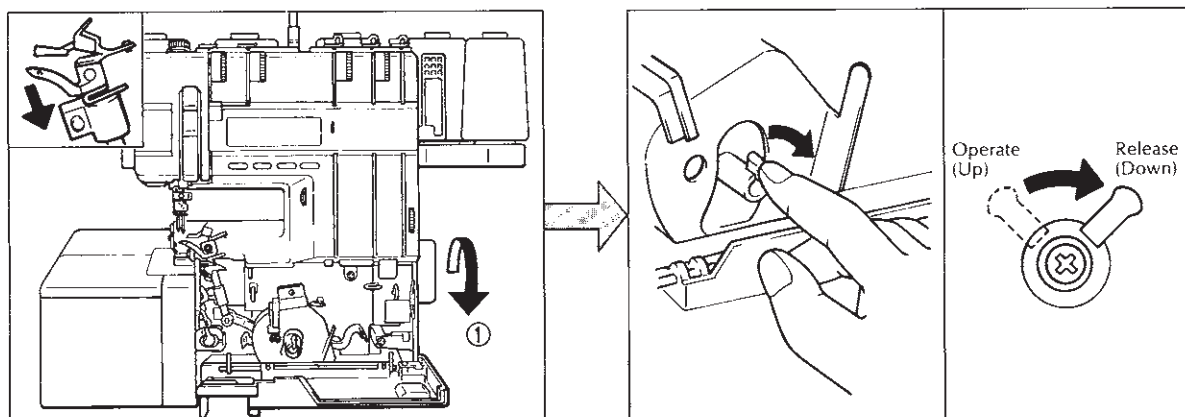

To lock down the upper looper

- 1) Turn the handwheel by hand in the direction of the arrow ① to lower the upper looper to its **lowest position**.
- 2) Next, move the chain stitch lever (upper looper release knob) in the direction of the arrow until it stops securely in the "Release" position (approx. 90°).
- 3) The upper looper will be automatically lowered and will not move up and down.

IMPORTANT!

After the upper looper has been locked and before starting to sew, turn the handwheel by hand one full revolution or more toward you ① to confirm that the upper looper has been locked and does not operate.

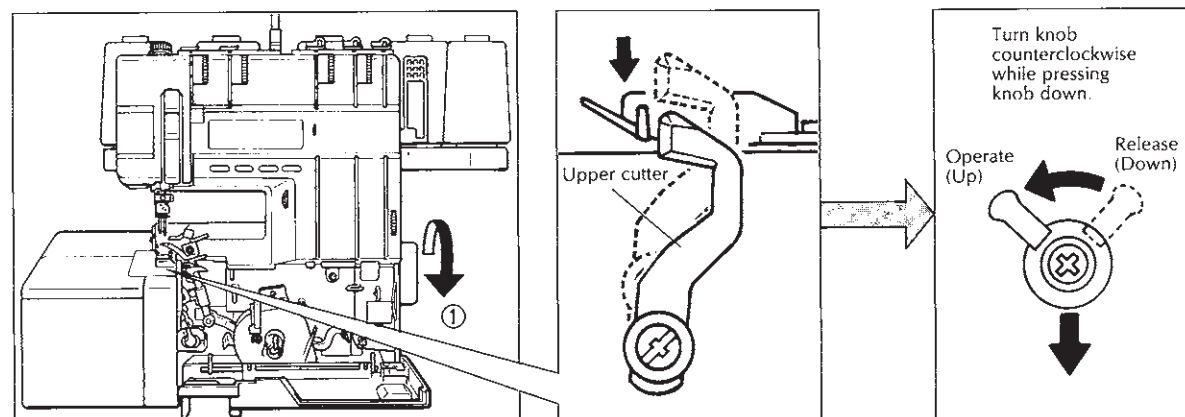

To return the upper looper to the normal position

- 1) Turn the handwheel by hand in the direction of the arrow ① to lower the upper cutter to its **lowest position**.
- 2) Next, turn the chain stitch lever (upper looper release knob) 90° so that it is in the "Operate" position.
- 3) Sometimes the chain stitch lever may not move fully back 90°. However, if the handwheel is turned 2–3 times by hand, the knob will automatically return to the "Operate" position. In this case, do not force the knob to turn.
- 4) The upper looper will be raised automatically and can then be operated.

IMPORTANT!

Always be sure to operate the upper looper after double chain stitch sewing has been completed. At this time, turn the handwheel by hand one full revolution or more in the direction of the arrow ① to confirm that the upper looper can now operate.

When operating the upper looper, remove cutter cover II.

2. Retracting the upper cutter

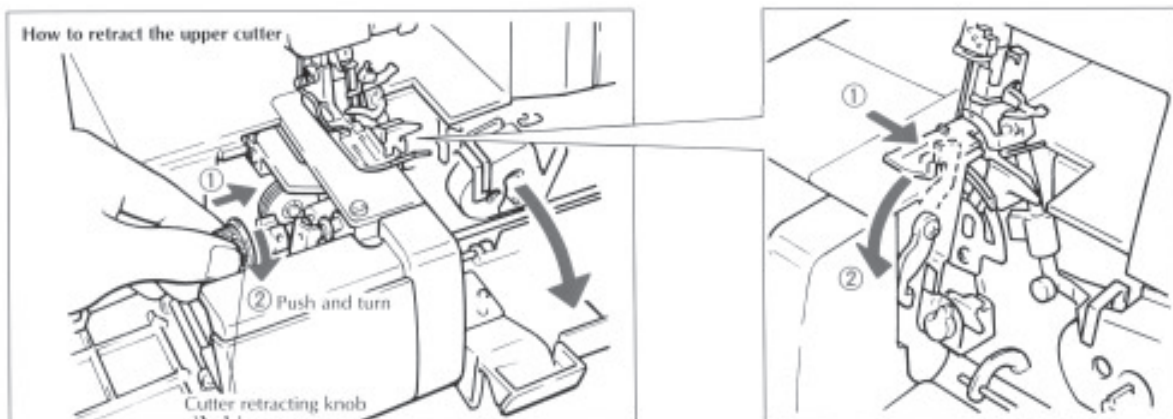

To sew without cutting the material

- 1) Raise the needle above the needle plate.
- 2) Open the side cover, and then push and turn the cutter retracting knob to retract the upper cutter.

CAUTION!

Set the overlock stitch width so that it is not wider than the scale on the stitch width control dial. If the overlock stitch width is set too wide, the upper looper will pull the edge of the material, which will cause problems with sewing.

※Before starting sewing, close the side cover.

NOTE

To trim while sewing double chain stitch

In this case, disengage the upper looper, and then start double chain stitch sewing with the cutter up.
Do not replace the cutter cover with cutter cover II at this time.

SETTING FOR DOUBLE CHAIN STITCH SEWING

3. Removal and installation of cutter cover II

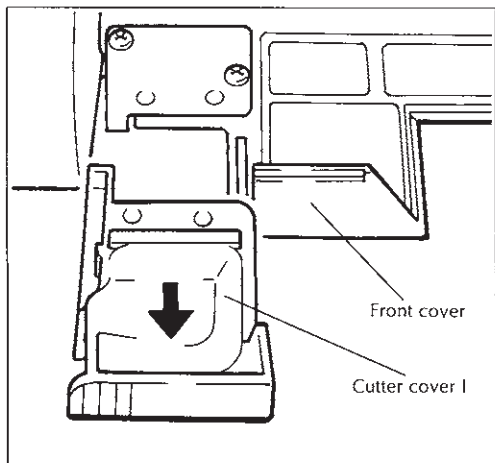

Installation of cutter cover II

- 1) Open the front cover and pull cutter cover I toward you to remove it.
- 2) Insert the cutter cover II.

CAUTION!

When using the cutter cover II, the cutter must be down and the upper looper disengaged.

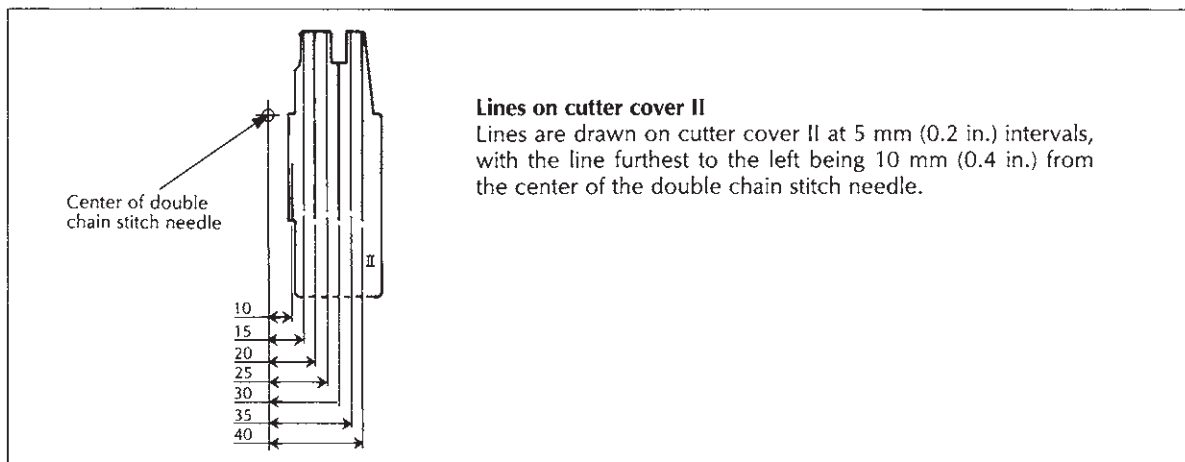
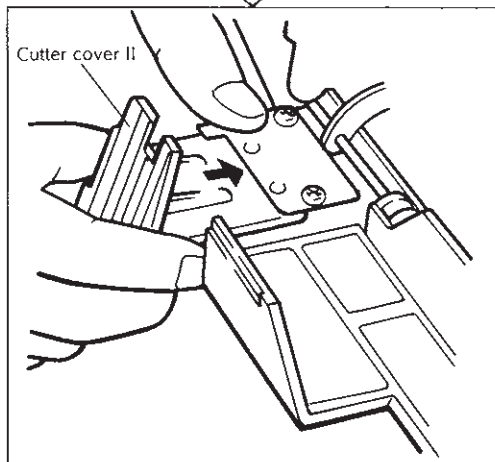

Lines on cutter cover II

Lines are drawn on cutter cover II at 5 mm (0.2 in.) intervals, with the line furthest to the left being 10 mm (0.4 in.) from the center of the double chain stitch needle.

SETTING FOR TWO-THREAD OVERLOCK STITCH SEWING

TWO-THREAD OVERLOCK STITCH

Thread in the following order:

- 1) Lower looper thread (blue)
- 2) Left needle thread (yellow) for wide or right needle thread (red) for narrow

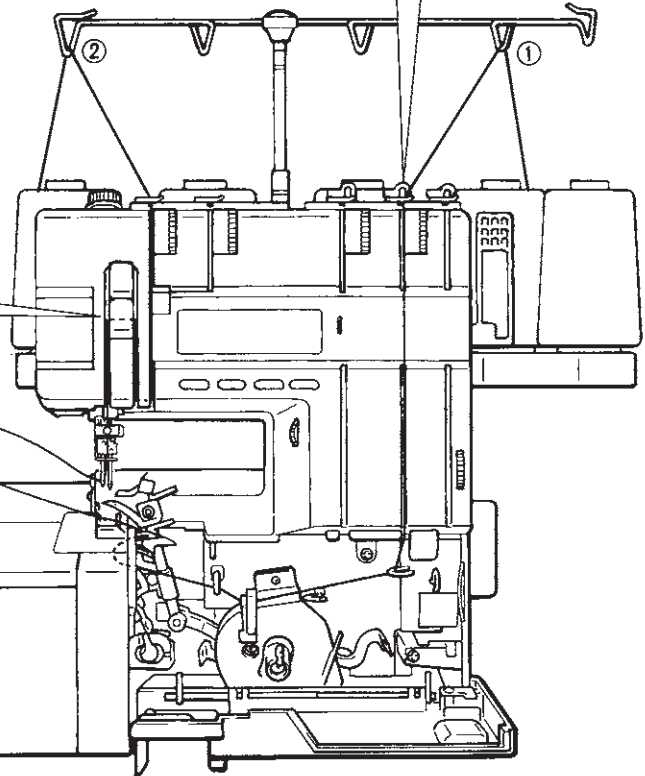
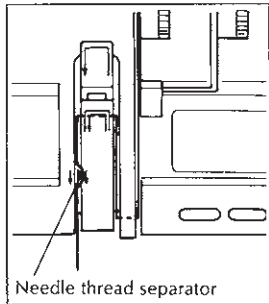
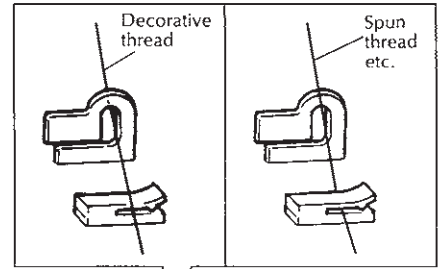
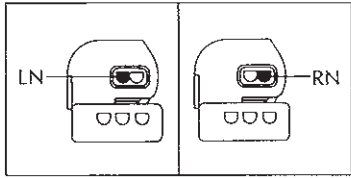

Pull out the thread about 10 cm (4 inches) away from you.

Two-thread converter lever

For two-thread sewing

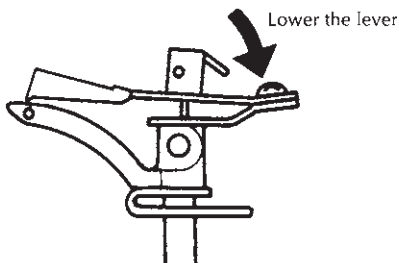

For three-, four-, five- and cover stitch thread sewing

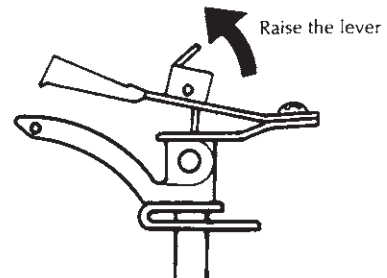

SEWING

Four-thread, three-thread or two-thread sewing

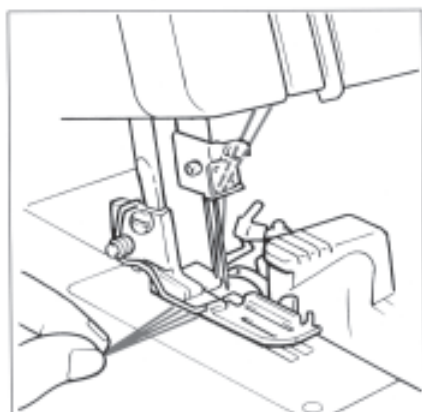

To start sewing

- * Thread the machine and pull out the threads about 15 cm (6 in.) to the left of the presser foot.
- * Place a scrap piece of the fabric you intend to use under the presser foot and sew a few stitches by turning the handwheel toward you by hand.
- * Check the stitch to see if it is uniform. If not, recheck the threading is correct.

IMPORTANT!

Make sure that you are familiar with the procedures at the sewing start before carrying out double chain stitch sewing. (Refer to page 28.)

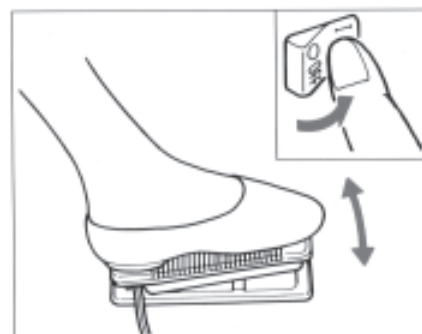

Operation

- * Turn on the main power switch and light switch.
- * When the pedal is lightly depressed, the machine runs at low speed, and as it is depressed further, the machine will increase speed.
- * With the scrap piece of fabric under the presser foot, lower the presser foot and test-sew.

NOTE

Guide the material gently by hand while sewing. Be careful not to pull too hard.

The machine will not operate and an error message will appear on the LCD when the presser foot is raised. In this case, lower the presser foot lever and then start sewing again.

To remove the work

- * When you reach the end of the fabric, continue sewing for about 5 cm (2 in.), leaving the 2" chain attached to the overlock. Then trim off the chain close to the material with a pair of scissors.

Chaining-off

- * After sewing the fabric, keep the foot control depressed slightly for a while (chaining-off). The threads will entwine themselves into a chain and be fed forward automatically.

If threads break during sewing

- * Remove the fabric and re-thread correctly (refer to pages 11–18, "THREADING" and "THREADING NEEDLES"). Put the fabric back under the presser foot and sew 3–5 cm (1.2–2.0 in.) over the previous stitches.

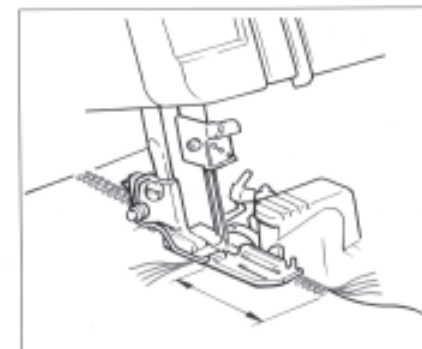
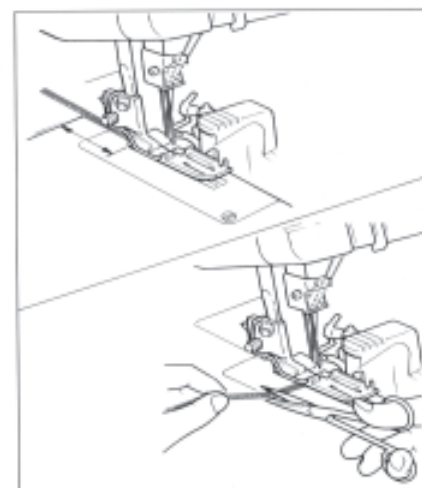

Five-thread or double chain stitch sewing

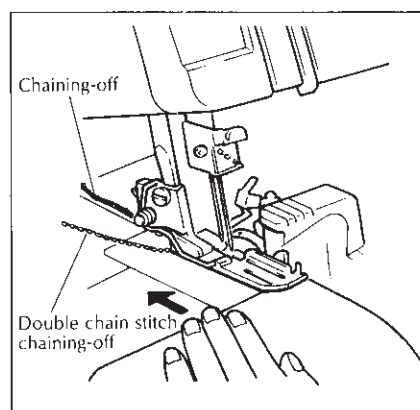
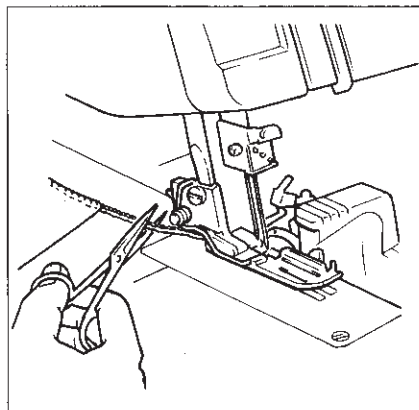
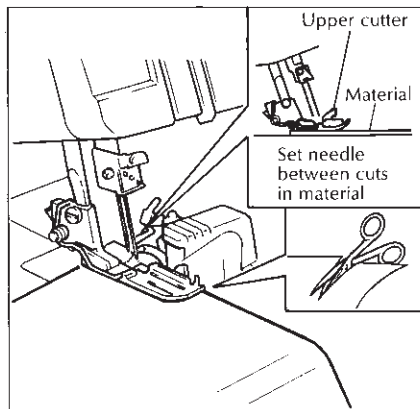

1. When carrying out five-thread or double chain stitch, first thread the machine for either technique, and then use scissors to trim a short section of the fabric. Then place the trimmed edge against the upper cutter so the needle begins sewing along the edge of the material.
2. Turn the handwheel gently two or three times to check that the threads are running smoothly, and then slowly start sewing.
3. When you have sewn to the edge of the material, keep sewing at low speed to sew past the edge of the material (Chaining-off). Pull the chain away in a diagonal direction, toward the back left corner of the machine. Cut off the extra thread about 5 cm (2 in.) from the edge of the material.
4. When continuing on to sew another piece of material, sew the next piece without raising the presser foot.
※When sewing a chaining-off stitch, it is not necessary to raise the presser foot.

CAUTION!

If the thread becomes tangled in the double chain looper, the double chain stitches will not be sewn properly. If these stitches are not being sewn properly, check the double chain looper. If it is tangled with thread, remove the tangled thread, rethread the chain stitch loopers, then the needle and re-sew.

THREAD TENSION ADJUSTMENT

Thread tension dials

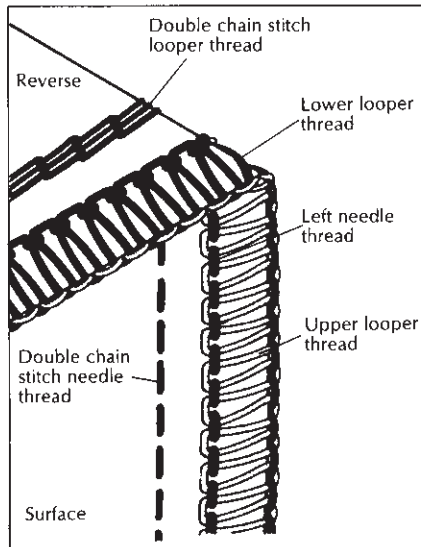
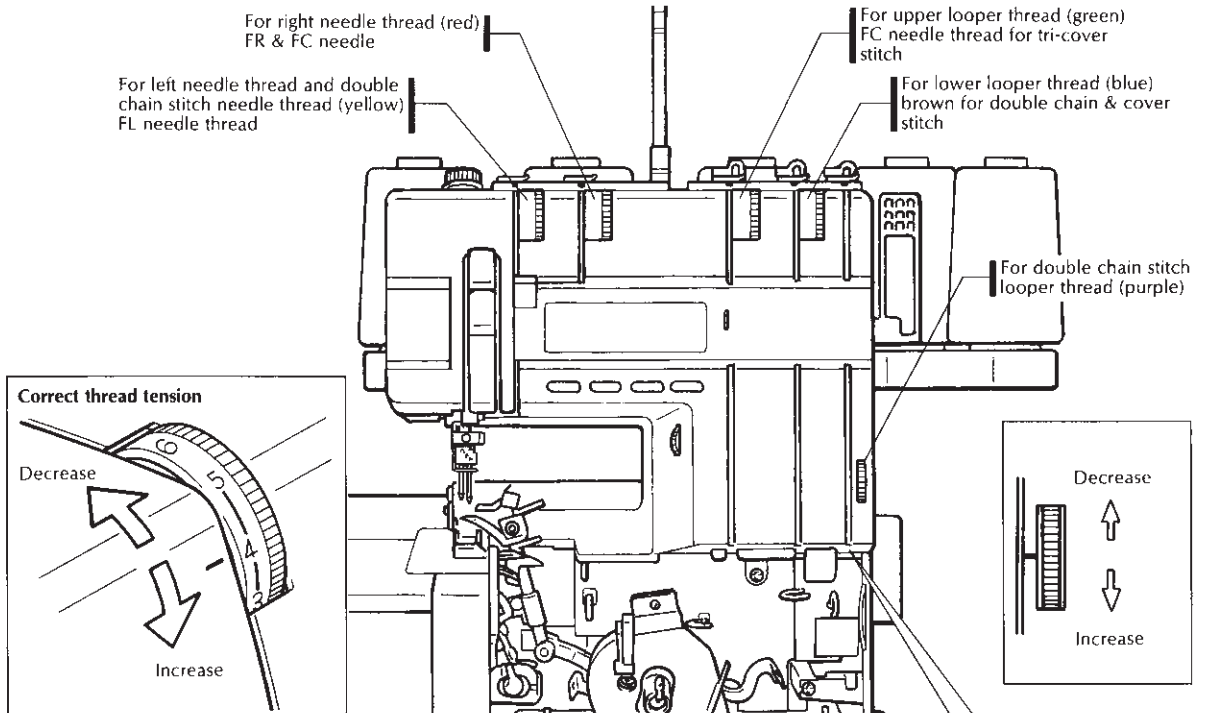

Tension control

Set tension dials at 4 for most serging. To fine tune the stitch, consult pages 36–38.

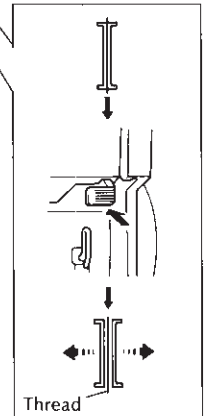

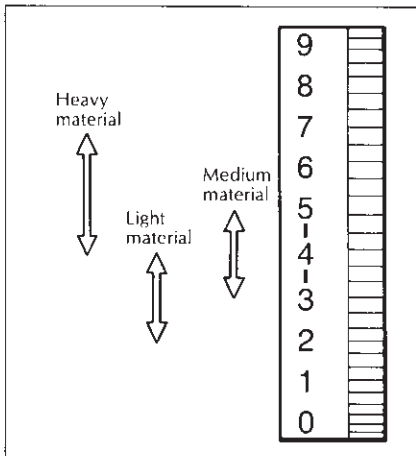

Thread tension scale

The thread tension may vary slightly depending on the type of material and the type and thickness of the thread. Therefore, adjust the tension to suit the sewing conditions. A balanced stitch length can be obtained if the tension is adjusted so that it is tighter (higher #) for thick materials and looser (lower #) for thin materials as shown in the illustration at left.

Order of thread tension adjustment

When you adjust the thread tension, do it in the following order:

FIVE-THREAD OVERLOCK STITCH

- 1) Left needle thread (red)
- 2) Upper looper thread (green)
- 3) Lower looper thread (blue)
- 4) Double chain stitch needle thread (yellow)
- 5) Double chain stitch looper thread (purple)

FOUR-THREAD OVERLOCK STITCH

- 1) Left needle thread (yellow)
- 2) Right needle thread (red)
- 3) Upper looper thread (green)
- 4) Lower looper thread (blue)

This is the easiest way to obtain correct thread tension.

THREAD TENSION ADJUSTMENT

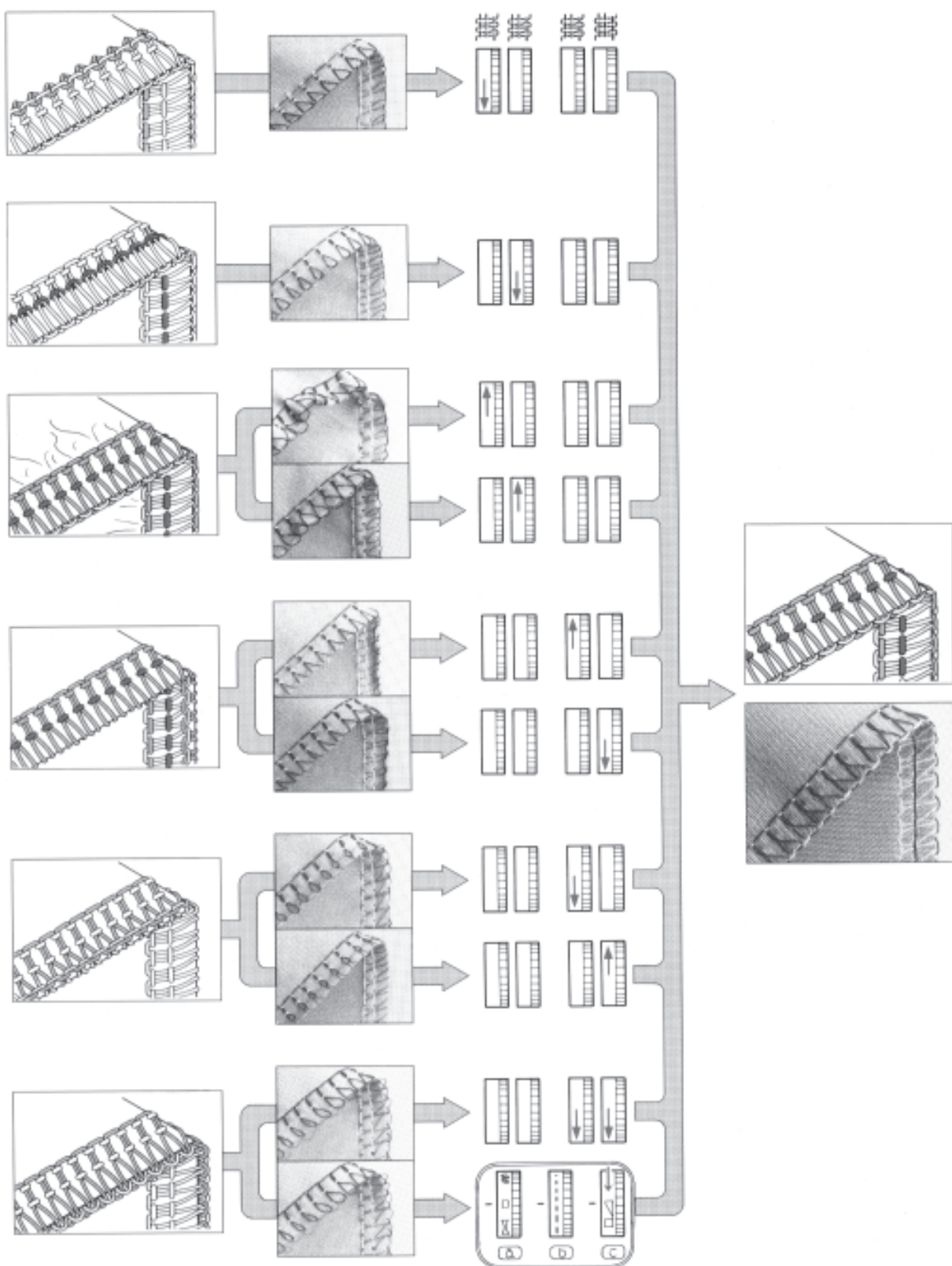

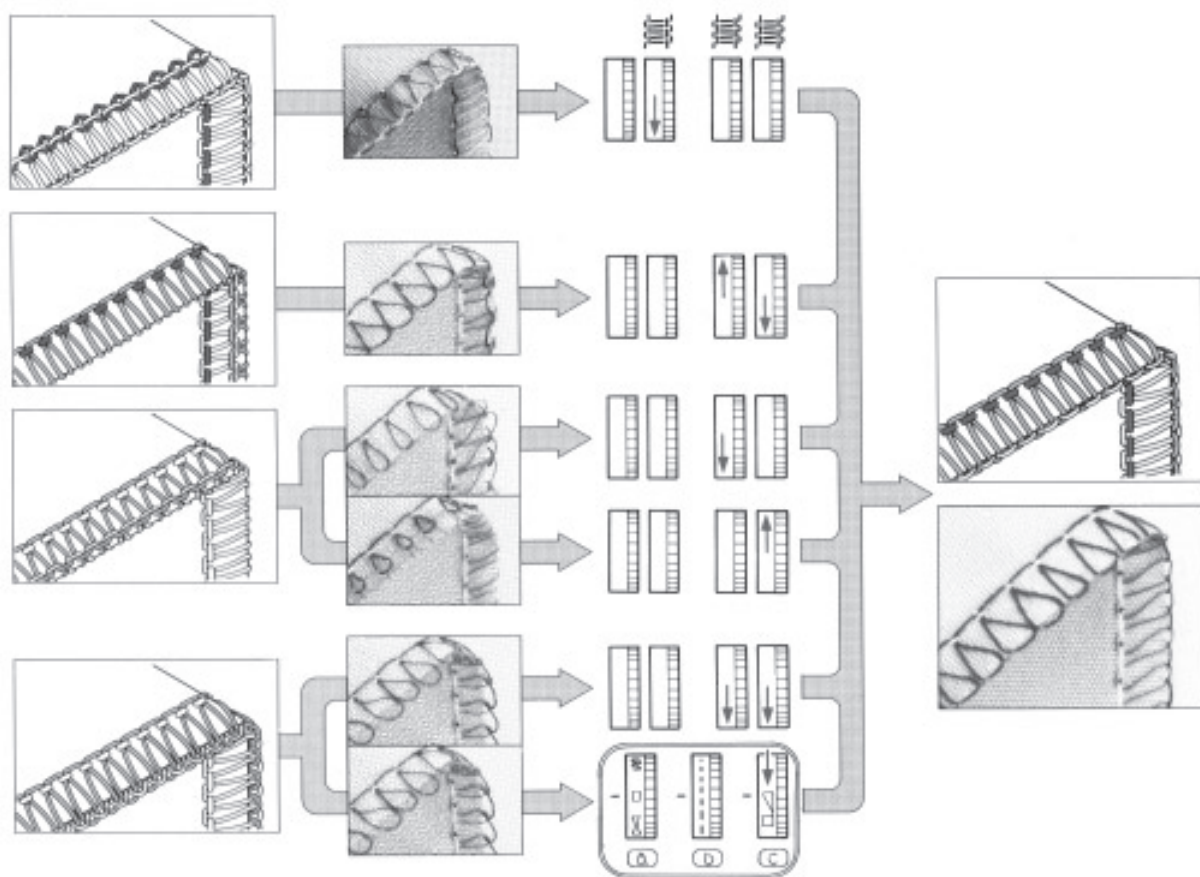

Double chain stitch looper

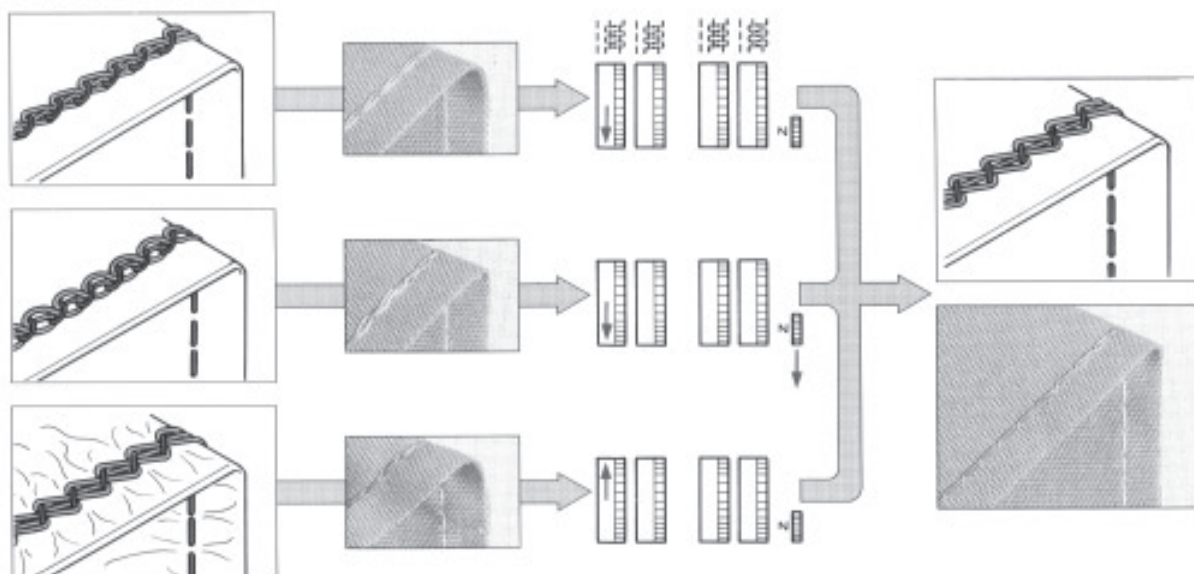

NOTE

Five-thread sewing is a combination of the above three-thread sewing and double chain stitch sewing.

RELATIONSHIP BETWEEN SEWING MATERIAL, THREAD AND NEEDLE

Materials		Stitch	Thread		Stitch length mm (in.)	Needle
Light material	Georgette Crepe de chine Lawn Organdy Tricot	Overlock stitch	Spun thread	#80-100	2.0-3.0 (0.08-0.12)	SCHMETZ 130/705 H #70 or #80
			Cotton thread	#80-100		
		Narrow overlock stitch/ Rolled edge stitch	(Needle thread) Polyester thread	#80	Less than 2.0 (0.08)	● Double chain stitch needle SCHMETZ 130/705H #90
			Nylon thread	#80 (Lower looper thread) Polyester thread		
Medium material	Poplin Gingham Broadcloth Gabardine Knitted	Overlock stitch	Spun thread	#60-80	2.5-3.5 (0.10-0.14)	SCHMETZ 130/705 H #80 or #90
				Cotton thread		
			Silk thread	#50-80		● Double chain stitch needle SCHMETZ 130/705H #90
			Polyester thread	#50-80		
			Nylon thread	#50-80		
Heavy material	Cashmere Tweed Denim Jersey	Overlock stitch	Cotton thread	#40-60	3.0-4.0 (0.12-0.16)	SCHMETZ 130/705 H #90
				Silk thread		
			Polyester thread	#30-60		● Double chain stitch needle SCHMETZ 130/705H #90 (Very heavy material #100)
			Nylon thread	#30-60		

IMPORTANT!

When you carry the machine with threads threaded, push the thread holder stand down to the lowest position and wind the threads onto each spool.

STITCH LENGTH AND STITCH WIDTH

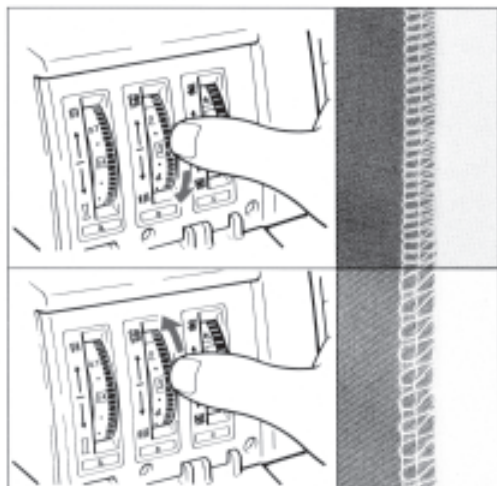

Stitch length

Open the control cover, then set the stitch length control dial to the proper position.

Minimum 1 mm (0.04 in.) <position R>

Standard 3 mm (0.12 in.) <position 3>

Maximum 5 mm (0.2 in.) <position 5>

REMARK

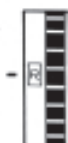

Position "R" on the stitch length control dial is used for narrow overlock stitch/rolled edge stitch. (Refer to pages 44–45.)

(TIP)

If you raise the presser foot, the stitch length control dial can be turned more easily.

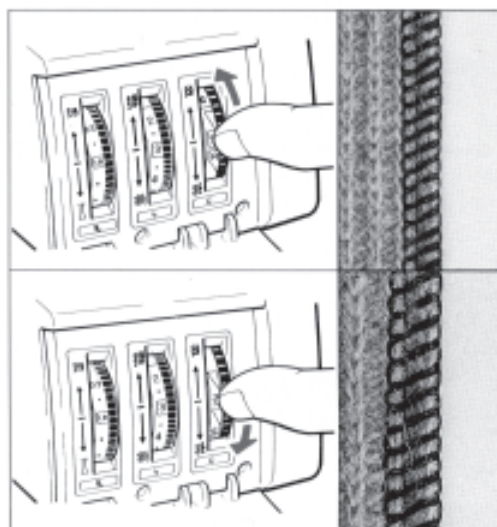

Stitch width

The stitch width can be adjusted by turning the stitch width control dial inside the control cover.

REMARK

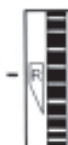

Position "R" on the stitch width control dial is used for narrow overlock stitch/rolled edge stitch. (Refer to pages 44–45.)

(TIP)

If you raise the presser foot and open the front cover, the stitch width control dial can be turned more easily.

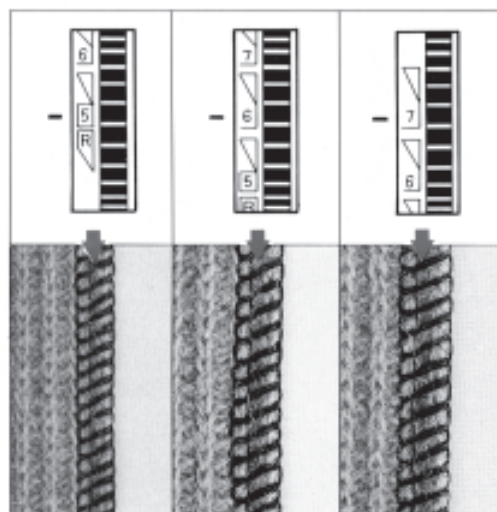

Dial No.	R	5 mm (in.)	6 mm (in.)	7 mm (in.)
5 thread-stitch	—	6 (0.24)	7 (0.28)	8 (0.31)
4 thread-stitch	—	5 (0.2)	6 (0.24)	7 (0.28)
3 thread-stitch with left needle	—	5 (0.2)	6 (0.24)	7 (0.28)
3 thread-stitch with right needle	Narrow overlock stitch/ Rolled edge stitch	3 (0.12)	4 (0.16)	5 (0.2)

For narrow overlock stitch/rolled edge stitch, refer to pages 44–45.

STITCH WIDTH AND CUTTING WIDTH FINE-TUNE ADJUSTMENT

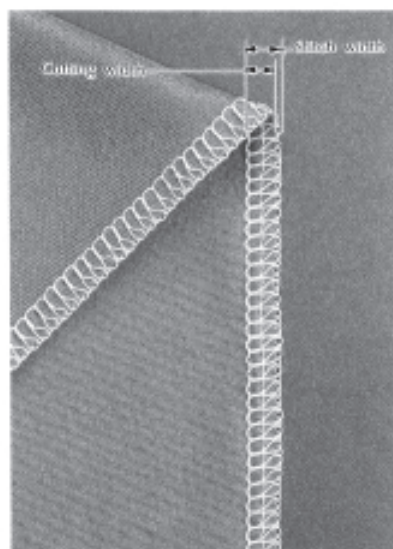

When you sew stretch materials, you sometimes will find the fabric stretches away from the overcasted edges. When this occurs you can eliminate the problem by fine adjustment of the stitch width control dial maintaining the stitch width while increasing the cutting width. This exclusive feature will ensure good sewing results for all materials.

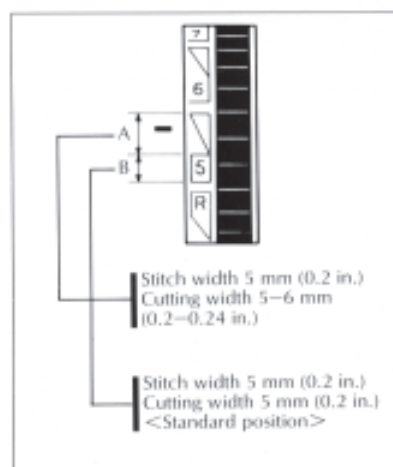

How to adjust?

When you turn the stitch width control dial (c), the stitch width can be set at 5, 6 or 7 mm (0.2, 0.24 or 0.28 in.) while the cutting width is increased gradually from 5 to 7 mm (0.2 to 0.28 in.). If you want to sew 5 mm (0.2 in.) stitch width but 5.5 mm (0.22 in.) cutting width when sewing stretch materials, you set the stitch width control dial within area "A" as illustrated. This will result in correct overcasting on stretch materials.

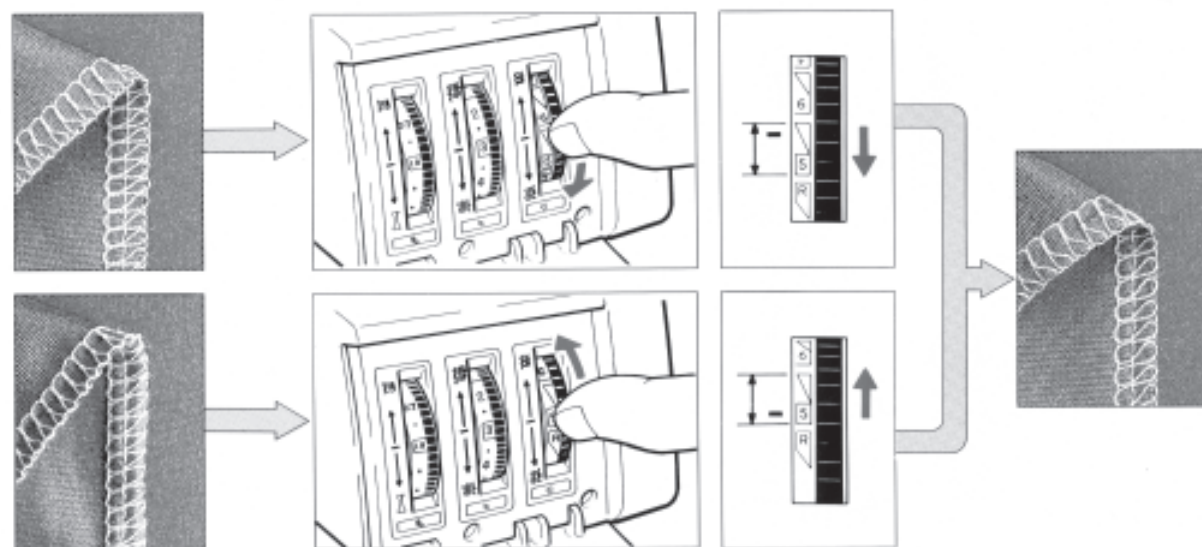

DIFFERENTIAL FEED

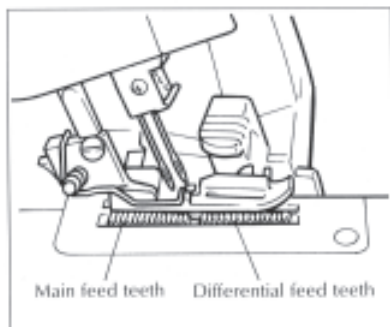

What is "differential feed"?

The machine is equipped with two feed teeth, of which the front one (the differential feed) can be adjusted to feed more or less fabric in relation to the rear one (the main feed).

It is adjustable between 0.7–2.0. The exact adjustment is dependent on the thickness and elasticity of the material. The stitch length also affects the adjustment. The longer the stitch, the more material is being fed forward.



How to adjust the differential feed

Open the control cover, then adjust the feed ratio as required by means of the differential feed control dial.

Example of application	Differential feed operation	Main feed teeth	Differential feed ratio	Differential feed teeth
To prevent puckering of thin materials	Holds the material taut while sewing		0.7–1.0	
Normal overlock sewing	Sews normally		1.0	
Gather lightweight fabric and prevent stretch in knits	Contracts the material while sewing		1.0–2.0	

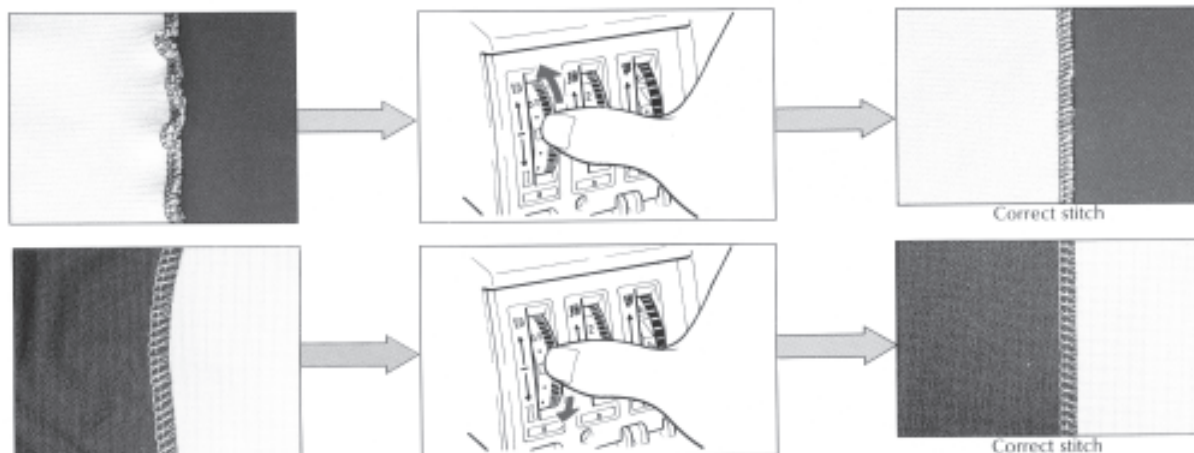

PRESSER FOOT

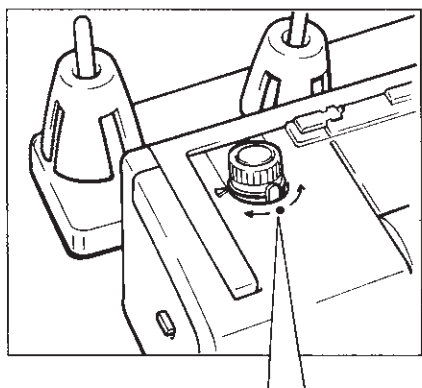

Adjustment of presser foot pressure

The pressure of the presser foot can be adjusted by turning the pressure adjustment dial.

Since the machine has already been adjusted to a pressure suitable for light and medium fabrics, no further adjustment is necessary except when sewing very heavy or very light and stretch material.

<p>Standard position</p> <p>Align the pressure indicator with the alignment mark.</p>	<p>Decrease</p>	<p>Light material Stretch material Knitted material</p>
	<p>Increase</p>	<p>Heavy material</p>

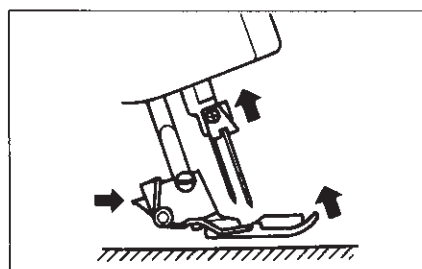

Changing the presser foot

- 1) Raise the presser foot lever.
- 2) Turn the handwheel to raise the needles to the highest position.
- 3) Press the button on the back of the presser foot ankle.
- 4) Raise the presser foot lever one more step, and then remove the presser foot.
- 5) To replace, place the presser foot so that the support pin is directly below the presser foot holder, and then lower the presser foot lever. The presser foot will snap on to the ankle.

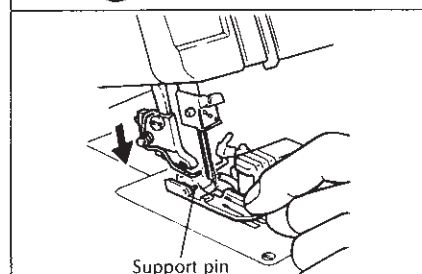
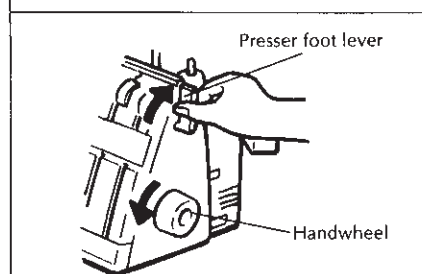

NARROW OVERLOCK STITCH/ROLLED EDGE STITCH

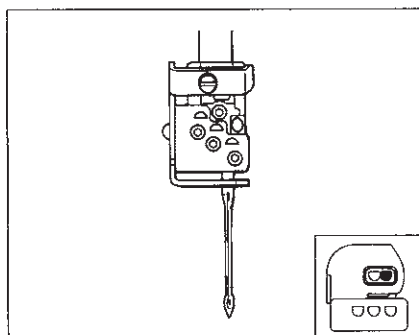

★ Thread the threads in the same way as when doing three-thread overlock sewing with the right needle.

1. Use the right needle only.
※ Lightly tighten the screws of the unused needle positions to secure.

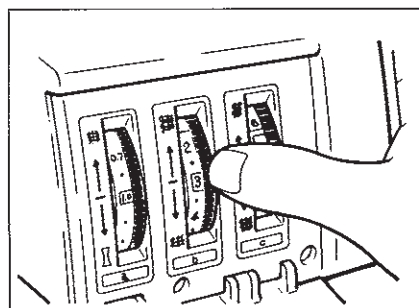

2. Adjust the stitch length and stitch width.
 - 1) Open the control cover.
 - 2) Set the stitch length control dial to "R."

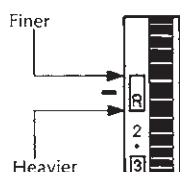

Adjust the stitch length within the range shown in the illustration at left in accordance with the type of material.

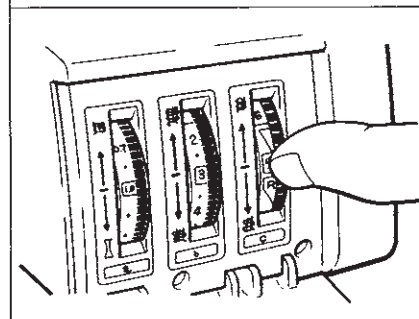

- 3) Set the stitch width control dial to "R."

(TIP)

For narrow overlock and rolled edge, use R needle, set stitch length control dial and stitch width control dial all to "R."

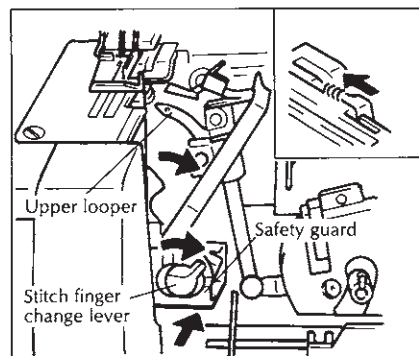

3. Swing away the movable wide stitch finger.
 - 1) Raise the presser foot lever.
 - 2) Gently pull the thread chain off the stitch finger.
 - 3) Open the front cover.
 - 4) Turn the handwheel to lower the upper looper to its lowest position.
 - 5) While pressing the safety guard, turn the stitch finger change lever to the right to swing away the movable stitch finger from the needle plate.

CAUTION!

* The safety guard can only be pressed when the upper looper is at its lowest position.

* The stitch finger lever should only be turned when the presser foot has been raised or removed.

NARROW OVERLOCK STITCH/ROLLED EDGE STITCH

Ratio chart of sewing material, thread and needle

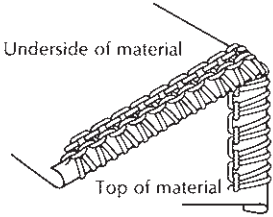
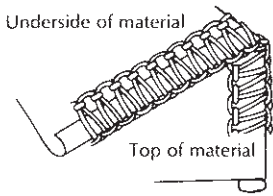
Rolled edge stitch		Materials	Thread	Right needle thread	Upper looper thread	Lower looper thread
	Light material Crepe de chine Georgette Lawn Organdy	Thread	Right needle thread	Nylon thread #80 Polyester thread #80	Wooly nylon thread Decorative thread	Nylon thread #80 Polyester thread #80
			Thread tension	3 (2-4)	3 (2-4)	6 (5-7)
				Red	Green	Blue
Narrow overlock stitch		Materials	Thread	Right needle thread	Upper looper thread	Lower looper thread
	Light material Crepe de chine Georgette Lawn Organdy	Thread	Right needle thread	Nylon thread #80 Polyester thread #80	Wooly nylon thread Nylon thread #80 Polyester thread #80	Nylon thread #80 Polyester thread #80
			Thread tension	4 (3-5)	4 (3-5)	4 (3-5)
				Red	Green	Blue

The thread tension may vary depending on the type of material and the type and thickness of the thread. Therefore, adjust the tension to suit the sewing conditions.

EXAMPLES OF SEWING APPLICATIONS FOR OVERLOCK SEWING MACHINES

1. Blind stitching with multi purpose foot

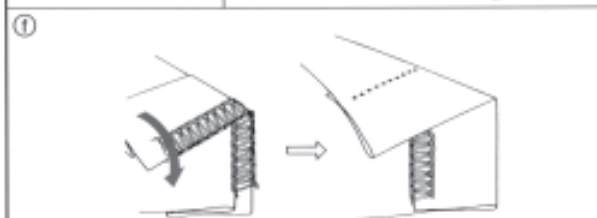
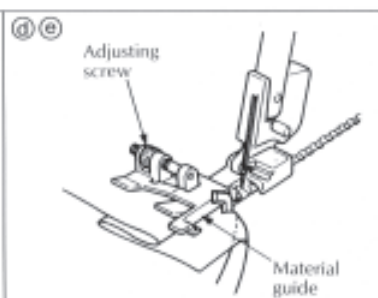
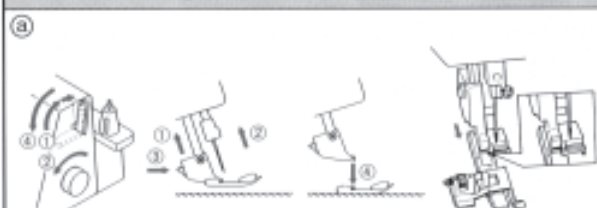

- Ⓐ Replace the presser foot with a blind stitch presser foot (multipurpose foot).
- Ⓑ Fold the material as shown in the illustration.
- ※ Sewing will be easier if a crease is ironed into the folded material before sewing.
- Ⓒ Raise the presser foot, set the material so it is under the needle, then lower the presser foot.
- Ⓓ Adjust the guide position of the presser foot with the adjusting screw so the needle is slightly catching the fold of the material. In this case, the thickness of the material is the criterion.
- Ⓔ While folding the material by hand, sew so the needle just catches the edge of the crease.
- Ⓕ Open up the material as shown in the illustration.
- ※ To adjust the position of the material guide, the same piece of material can be used to make a test sewing.
- ※ An attractive finish can be obtained by using a thread the same color as the material and which is as fine as possible.

☆ Use the multipurpose presser foot.

2. Flatlock stitching with multi purpose foot

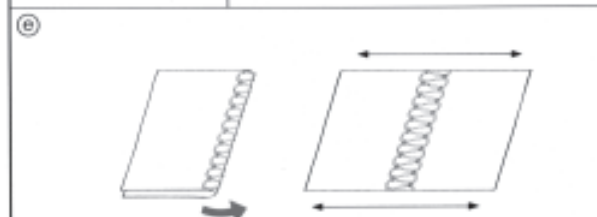
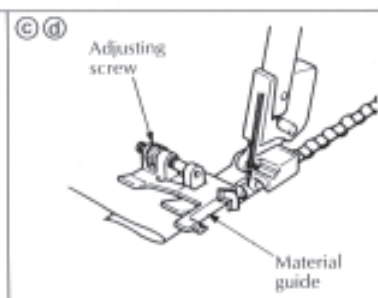

- Set for 3-thread sewing with following thread tension. (For 2 thread flat lock, consult the sewing advisor)
- Needle: 0
- Upper looper: normal
- Lower looper: increase slightly
- Ⓐ Replace the presser foot with a blind stitch presser foot (multipurpose foot).
- Ⓑ Fold the material as shown in the illustration. Then raise the presser foot, set the folded edge of material under the needle, then lower the presser foot.
- ※ Set the stitch width control dial to "7."
- Ⓒ Adjust with the adjusting screw so the needle moves down to a position 2.5–3.0 mm (0.1–0.12 in.) inside the folded edge of the material with the loops off the edge of the material.
- Ⓓ While guiding the material with your hand, sew at a constant speed.
- Ⓔ Pull the material open (flat) as shown in the illustration.
- ※ This method is not suitable for thin materials.
- ※ To adjust the position of the material guide, the same type and thickness of material can be used to make a test sewing.

☆ Use the multipurpose presser foot.

EXAMPLES OF SEWING APPLICATIONS FOR OVERLOCK SEWING MACHINES

3. Sewing tucks with multipurpose foot

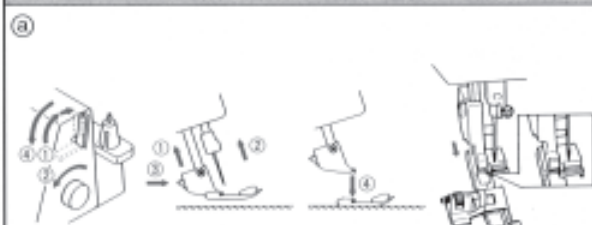

Use the multipurpose presser foot guide and make narrow overlock stitches to produce seams in the form of tucks at equal distances from each other. For thin materials, it's a good idea to choose a fine thread.

- ⓐ Replace the presser foot with a blind stitch presser foot (multipurpose foot).
- ⓑ Set up the machine for narrow overlock stitching. (Refer to pages 44–46.)
- ⓒ First, draw regular-spaced marking lines on the material as guides for pin tucking.
- ⓓ Adjust so the guide of the multipurpose presser foot is aligned with the line on the right of the stitch finger.
- ⓔ Align the crease with the guide and insert the material up to the needle.
- ⓕ Sew along the marking lines.
- ⓖ Continue sewing until all marking lines have been sewn.

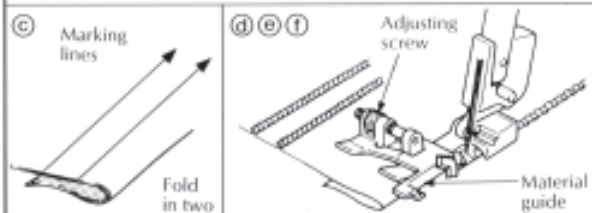

★ Use the multipurpose presser foot.

4. Decorative stitching

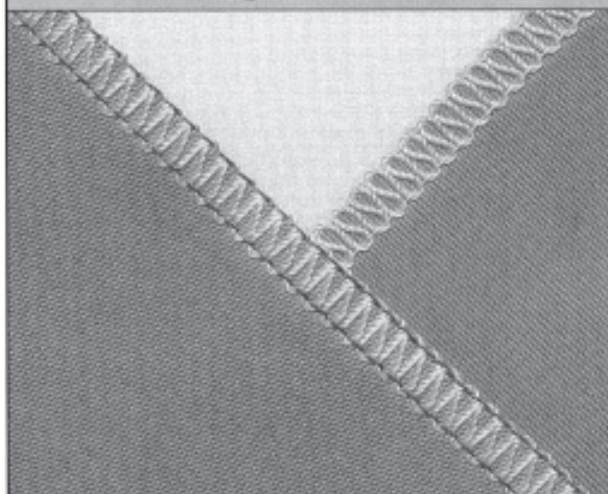

Attractive decorative stitches can be made through different combinations of material and thread. Decorative thread with a high thread count or extremely fine thread can be used as the upper looper thread to produce decorative stitching with an even stitch length.

Adjust tension as needed – the basic guideline is, the heavier the thread, the lower the tension.

★ Use the standard presser foot.

Other special presser feet (optional)

1. Elastic/Taping presser foot

2. Pearl presser foot

3. Piping presser foot

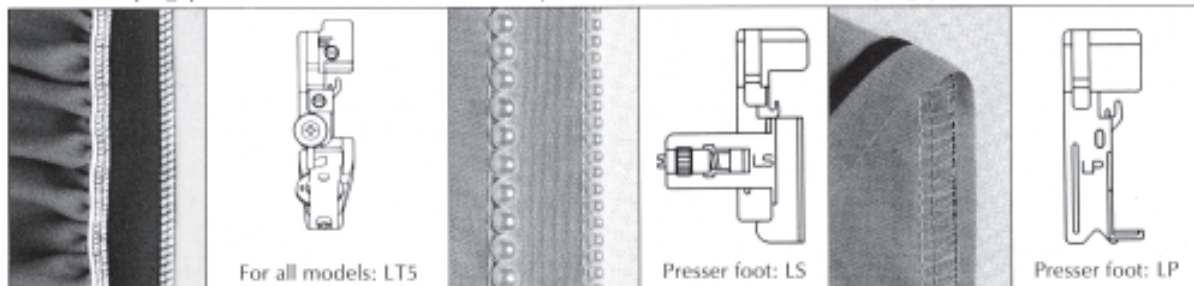











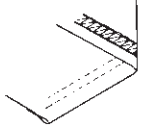

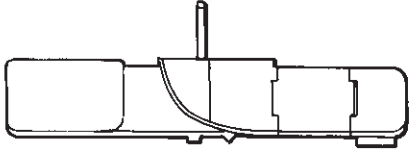
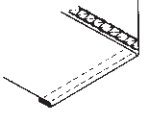

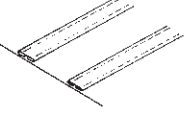
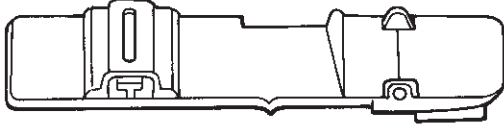
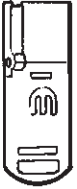
For all models: LT5

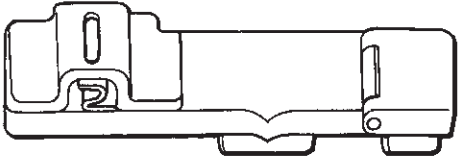
Presser foot: LS

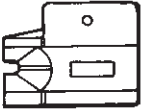
Presser foot: LP

COVER STITCH ATTACHMENT SET (OPTIONAL)

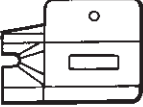
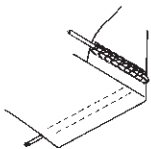
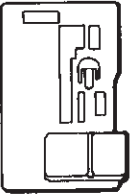
SET No. XB0403001

 <p>SINGLE DOWN TURN FELLER (A)</p>			
 <p>HEMMER (B)</p>			
<p>BIAS TAPE FOLDER</p> 			
<p>BELT LOOP FOLDER</p> 			
<p>BIAS BINDER (S)</p> 			
<p>BIAS BINDER (L)</p> 			
 <p>PIPING</p>			

PERFORMANCE PROBLEMS

Whenever sewing difficulties are encountered, review the section of the instruction book that explains about the operation you are performing to make sure you are using the machine correctly. Change your needles and rethread if the problem persists. The following check list may help you correct any problems. If you still have difficulties, contact your nearest authorized service center.

Problem	Cause	Remedy	Page
1. Skipped stitches	Needle is bent, or tip of needle is broken.	Replace with a new needle.	8-10
	Needle is incorrectly installed.	Install correctly.	8-10
	Thread is incorrectly threaded.	Thread correctly.	11-17, 27-28
	Presser foot pressure is too light.	Turn the presser foot pressure adjustment dial to the right to increase the pressure.	43
	Incorrect type of needle is being used.	Use a SCHMETZ 130/705H	39
2. Stitch tension is incorrect.	Thread tension is incorrect.	Refer to "Thread tension adjustment".	35-38
	Stitch width is inappropriate.	Refer to "Stitch width and cutting width fine-tune adjustment".	41
	Thread is incorrectly threaded.	Thread correctly.	11-17, 27-28
3. Thread breaks.	Thread is incorrectly threaded.	Thread correctly.	11-17, 27-28
	Thread is feeding off spool incorrectly.	Check that thread is not hooked on thread guide.	11-17
	Thread tension is too tight.	Refer to "Thread tension adjustment".	35-38
	Needle is bent, or tip of needle is broken.	Replace with a new needle.	8-10
	Needle is incorrectly installed.	Install correctly.	8-10
4. Material is puckered.	Thread tension is too tight.	If sewing with thin material, reduce the tension as necessary.	36
	Presser foot pressure is too tight.	Turn the presser foot pressure adjustment dial to the left to decrease the pressure.	43
	Stitch width is inappropriate.	Refer to "Stitch width and cutting width fine-tune adjustment".	41
	Thread is incorrectly threaded, or thread is feeding incorrectly.	Thread correctly.	11-17
	Differential feed adjustment is incorrect.	Refer to "Differential feed".	42
5. Material does not feed.	Presser foot pressure is too light.	Turn the presser foot pressure adjustment dial to the right to increase the pressure.	43
	Stitch length is not appropriate for the material.	Set the stitch length correctly.	40
	Needle plate is not on correctly.	Snap needle plate on correctly.	18
6. Needle breaks.	Needle is bent, or tip of needle is broken.	Replace with a new needle.	8-10
	Needle set screw is loose, or needle is incorrectly installed.	Install correctly.	8-10
	Material is being pulled too tightly.	Do not push or pull the material too much while sewing.	33
7. Sewing machine does not operate.	The power cord is unplugged from the power supply, or the power switch is not switched on.	Plug in the power cord, or turn the switch on.	33
	Presser foot is raised. Front door is open.	Lower the presser foot. Close door.	33
8. Nothing appears on the LCD	Contrast adjustment dial is incorrectly positioned. Machine is unplugged.	Turn the LCD contrast adjustment dial upward. Plug in the power cord.	1

CHANGING THE LIGHT BULB

CAUTION!

Always be sure to turn off the power before carrying out the following operation.

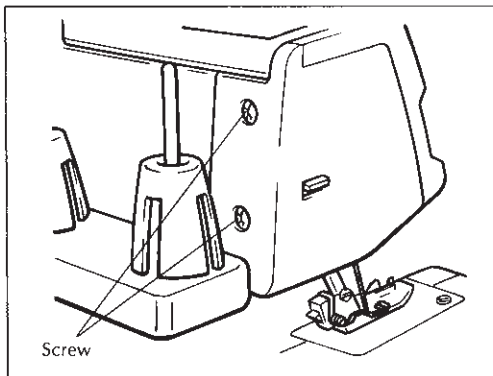

Changing the light bulb

Remove the lamp cover as shown in the illustration. Take out the light bulb and replace it with a new one.

* A new light bulb (8V, 2.4W, Part No.X50228-001) can be purchased at your nearest authorized dealer.

* When removing the lamp cover, be careful not to tug the cord which is attached to the cover.

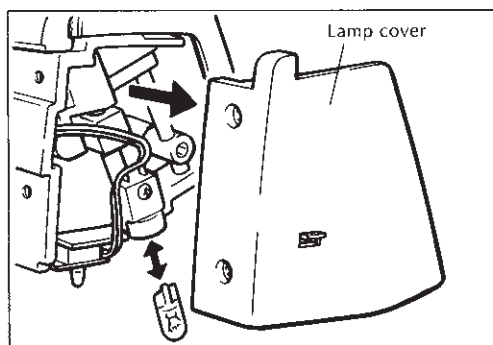

Retracting the upper cutter

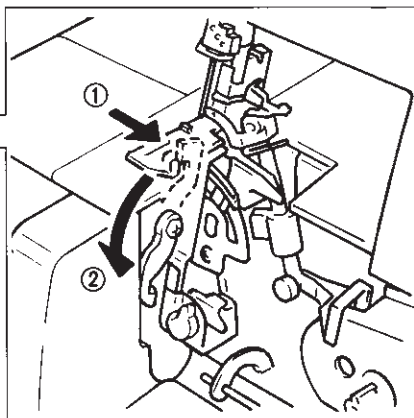
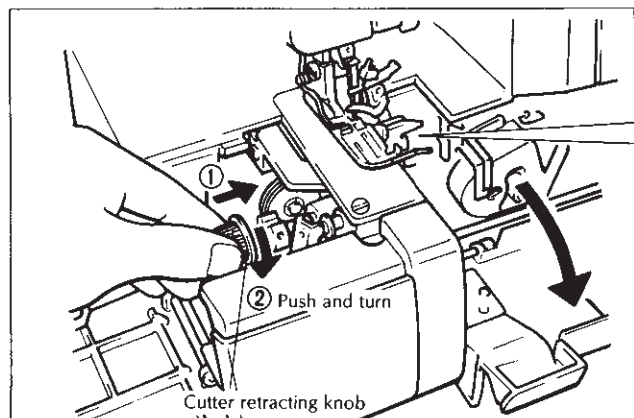

To sew without cutting the material

- 1) Raise the needle above the needle plate.
- 2) Open the material plate cover (front), and then push and turn the cutter retracting knob to retract the upper cutter.

CAUTION!

Set the overlock stitch width so that it is not wider than the scale on the stitch width control dial. If the stitch is set too wide, the upper looper will pull the edge of the material, which will cause problems with sewing. Remember all stitches except double chain stitch, you must still sew along the edge.

※Before starting sewing, close the material plate cover (front).

MAINTENANCE

CAUTION!

Always be sure to turn off the power before carrying out the following operation.

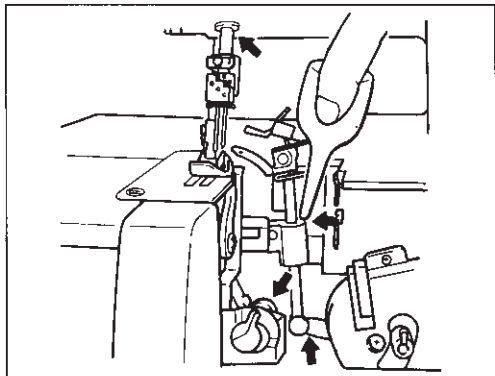

Oiling

For smooth and silent operation, the moving parts of the machine should be oiled periodically. (See illustration.)

REMARK:

Oil once or twice a month if the machine is used normally. If the machine is used more often, oil once a week. Always use high quality sewing machine oil.

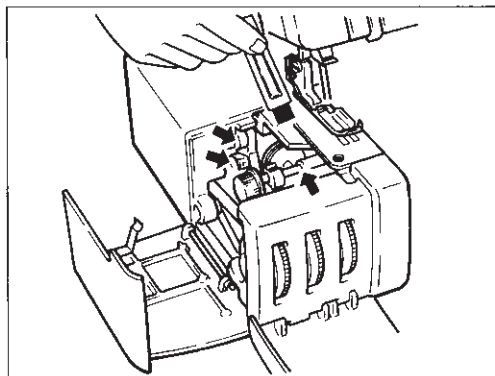

Cleaning

Periodically open the front cover (See pages 1-10) and clean the parts inside the machine using the accessory cleaning brush.

